

Honeywell



HON 380 gas pressure regulator with HON 673/674 controller

User and maintenance instructions
Spare parts

Contents

1	General considerations	4
1.1	About this user manual	4
1.2	About the safety notices	5
2	Description	7
2.1	Intended use	7
2.2	Device models	8
2.3	Labels/Markings	9
2.4	Identifying the device	10
2.5	Physical design and operation	11
2.6	Technical specifications	15
3	Safety	19
3.1	Basic safety rules	19
3.2	Requirements concerning the workforce, personal protective gear, workplaces	20
4	Basics for installing the device in a pipe	23
4.1	Installation example	23
4.2	Meter run characteristics	24
4.3	Operating and measuring lines	26
5	Transport and installation	27
5.1	Transporting the gas pressure regulator	27
5.2	Installing the gas pressure regulator	28
5.3	Installing the device connections	30
5.4	Checking the system for leaks	31
6	Adjusting the settings of the device	33
6.1	Adjusting the regulator unit setpoint	33
6.2	Adjusting the throttle valve on the measuring line of the regulator unit	36
7	Malfunctions	37
7.1	Malfunctions	37
8	Maintenance	39
8.1	Maintenance schedule	39
8.2	Preparing for the maintenance	40
8.3	Starting maintenance	41
8.4	Removing the regulator unit	43
8.5	Dismounting the controller	45
8.6	Performing maintenance on regulator unit	47
8.6.1	Performing maintenance on regulator unit RE1	47
8.6.2	Performing maintenance on regulator unit RE2	52
8.6.3	Performing maintenance on regulator unit RE0	57
8.7	Installing the regulator unit	61
8.8	Maintaining the monitoring device	62
8.9	Installing the controller	62
8.10	Completing the maintenance	63

9	Storage, removal, and disposal	64
9.1	Storing the device	64
9.2	Disassembling the device	65
9.3	Disposing of the device	66
10	Appendix	67
10.1	Additional information regarding spare parts	67
10.2	Spare parts kit for HON 380 with RE1	69
10.3	Spare parts kit for HON 380 with RE2	71
10.4	Spare parts kit for HON 380 with RE0	75
10.5	Lubricants	78

1 General considerations

Contents

Topic	Page
About this user manual	4
About the safety notices	5

1.1 About this user manual

Validity and purpose	<p>This user manual applies for gas pressure regulator HON 380 in combination with controller HON 673/674.</p> <p>This user manual provides all individuals with the information required for the safe handling in connection with the following tasks:</p> <ul style="list-style-type: none"> ▪ Transport ▪ Installation ▪ Start-up ▪ Set-up ▪ Maintenance ▪ Decommissioning, disassembly, renewed start-up, storage and disposal <p>Note: Detailed information on the HON 673/674 controller can be found in the component documentation included in delivery.</p>
Target group	<p>This user manual is intended for anyone working with the product:</p> <ul style="list-style-type: none"> ▪ Transportation personnel ▪ Installation personnel ▪ Set-up and operating personnel ▪ Maintenance and service personnel
Illustration	<p>Honeywell offers products with identical functions in a number of different sizes. For this reason, we are unable to guarantee that illustrations in this user manual coincide with the dimensions of your product. In these cases, the illustrations should be viewed as a concept sketch.</p>
 Safety	<p>Failing to observe the information provided in this document may lead to injuries, including death and material damages.</p> <p>To ensure the safety, any persons handling the product must have read and understood the following parts of this document before they start with any work involving it:</p> <ul style="list-style-type: none"> ▪ the chapter entitled Safety ▪ the chapters that describe the work to be done
Copyright notice	<p>Unless explicitly permitted, the disclosure as well as duplication of this document, the exploitation and communication of its contents are prohibited. Any breach or infringement will result in liability for damages. All rights reserved in the event of patent, utility model or registered design registration.</p>

Copyright

© Copyright 2022 by
 Honeywell Process Solutions
 Honeywell Gas Technologies GmbH
 Osterholzstraße 45
 34123 Kassel
 GERMANY

Tel: +49 561 5007-0
 Phone number for service: +49 561 5007-180
 Fax: +49 561 5007-107
 Fax number for service: +49 561 5007-108
 E-mail: gas-ks@honeywell.com
 Website:
 www.honeywellprocess.com
 www.hongastec.de
 Printed in Germany

Details about the manufacturer's liability

The manufacturer is not liable for damages and malfunctions arising from non-observance of this user manual and the other applicable documents.

Constructive changes

The written approval from Honeywell Gas Technologies GmbH, Kassel, is required for any modifications and additions to the product. Any violation will void the legal liability for consequences arising thereof.

1.2 About the safety notices



Meaning

The information contained in the safety notices is intended to prevent personal injury. Safety notices contain the following information:

- Nature and source of the danger
- Possible consequences associated with the non-observance of the notice
- Procedures for the prevention of personal injury

Types of safety notices

This document contains the following types of safety notices:

Type of safety notice	Description	Sign
Basic safety notices	Superordinate safety notices not relating to a specific task: <ul style="list-style-type: none"> ▪ They contain a summarized description of hazards, risks and safety procedures associated with the handling of the device. ▪ Their purpose is to inform and educate the user about an existing danger and about practicing behavioral safety. ▪ They are suitable as safety instruction for all employees handling the device. 	Recognizable by the heading of the chapter
Instruction-related safety notices	Safety notices containing specific instructions relating to the entire manual or a group of manuals	<div style="border: 1px solid black; padding: 2px; display: inline-block;">  </div> <div style="border: 1px solid black; padding: 2px; display: inline-block;">  </div> <div style="border: 1px solid black; padding: 2px; display: inline-block;">  </div>

Type of safety notice	Description	Sign
Step-related safety notices	Safety notices containing specific instructions relating only to the step	DANGER WARNING CAUTION
Additional safety notice	Instruction to observe certain safety notices with reference to a location in the document where safety notices containing specific information about dangers, risks and specific instructions for safety procedures can be found	

Danger levels

The safety notices containing specific instructions are identified with a signal word. The signal word represents a certain danger level:

Danger level	If you fail to follow the instruction, then ...	And the consequence is ...
DANGER	an accident will happen	serious bodily injury or death.
WARNING	an accident may happen	possible serious bodily injury or death.
CAUTION	an accident may or will happen.	minor or moderate bodily injury.

Warnings about material damages

Warnings about possible material damages are identified with the word **Attention** in this document.

2 Description

Contents

Topic	Page
Intended use	7
Device models	8
Labels/Markings	9
Identifying the device	10
Physical design and operation	11
Technical specifications	15

2.1 Intended use

Intended use

The HON 380 direct-acting gas pressure regulator must be used and operated exclusively with a compatible controller made by Honeywell. The gas pressure regulator is to be used in combination with a controller to provide a safety-shut off function in a regulating line.

Depending on the type, the gas pressure regulator can be used to maintain the outlet pressure of a gas constant within the regulating line, regardless of the influence of disturbance variables such as pressure changes and/or changes in consumption.

As a gas pressure regulator, it can be used in transfer stations used in gas transportation networks, as well as in power plants and industrial facilities. Gas pressure regulator HON 380 with controller HON 673/HON674 is suitable for use with natural gas or dry, non-aggressive industrial gases.

Note: The utilization limits of the device with regard to the medium, operating pressure and operating temperature can be gathered from the type plate attached on the device or the technical specifications.

The use under different operating conditions must be coordinated in consultation with the manufacturer.

Limitations of use

Please observe the following limitations of use:

- Do not use the device for any media other than those mentioned in the intended use or those discussed with and approved by the manufacturer.
- Do not use the device in any installation position other than the one documented in this user manual.
- Do not use the device against the direction of flow specified on the device and in the user manual.
- When replacing defective parts, only use original spare parts or manufacturer-approved standard parts.
- Do not attempt to modify or remodel the device on your own.

2.2 Device models

Gas pressure regulator versions

The gas pressure regulator HON 380 in combination with a HON 673/HON 674 controller is available in a number of versions. There are different versions of the controller and of the regulator.

HON 380 gas pressure regulator versions

The following table shows which models are available:

Nominal diameters of 1" (DN25), 2" (DN50), 3" (DN80), and 4" (DN100) each with			
Flange facing as defined by standard	Pressure rating	Maximum operating pressure [bar]	Flange facing
ASME B16.5	Class 150	20	Raised face
DIN EN 1092-1	PN 16	16	B flange

Regulator unit versions

The following table shows which models are available:

Regulator unit (RE):	Setpoint range	Body			
		DN 25	DN 50	DN 80	DN 100
RE1	20 mbar to 1000 mbar	X	X		
RE2	20 mbar to 1000 mbar		X	X	X
RE0	1000 mbar to 2000 mbar	X	X	X	X

HON 673 controller models

The comparator stage as an individual component is executed in four models with different designs in dependence on the control range (W_d) of the controller:

Control range W_{dso}	Design for upper response pressure
25 to 2300 mbar	K1a: Diaphragm measuring unit
400 to 5200 mbar	K2b: Diaphragm measuring unit
Control range W_{dsu}	Design for lower response pressure
10 to 300 mbar	K1a: Diaphragm measuring unit
60 to 400 mbar	K2b: Diaphragm measuring unit

HON 674 controller models

The comparator stage as an individual component is executed in three models with different designs in dependence on the control range (W_d) of the controller:

Control range W_{dso}	Design for upper response pressure
40 to 500 mbar	K4: Diaphragm measuring unit
200 to 1500 mbar	K5: Diaphragm measuring unit
600 to 4500 mbar	K6: Diaphragm measuring unit

Control range W_{dsu}	Design for lower response pressure
5 to 60 mbar	K4: Diaphragm measuring unit
15 to 120 mbar	K5: Diaphragm measuring unit
40 to 300 mbar	K6: Diaphragm measuring unit

Versions and designs in this user manual

The *technical specifications* and the *Maintenance* section, as well as the spare parts lists and spare parts drawings in the *appendix*, describe all the gas pressure regulator versions and all the models corresponding to the standard for this device type. Special-purpose versions are identified with “SO” in the inspection certificate, which is included with the gas pressure regulator.

However, other versions and models will be covered specifically as well when there are important differences that need to be pointed out.

If you have trouble understanding the information in this documentation, contact the manufacturer without fail before starting any work on the device.

2.3 Labels/Markings

Illegible labels

⚠ WARNING

Illegible information on the device poses a risk of injury due to resulting erroneous operation, use, or installation.

Labels, as well as inscriptions and stamping on the device, can eventually become soiled or otherwise unrecognizable to such an extent that users will not be warned effectively of hazards and may be unable to follow required operating instructions. This will pose a risk of injury.

- ⇒ Make sure to always keep all relevant labels in good condition so that they will be easily legible.
- ⇒ Immediately replace damaged and missing labels.

Gas pressure regulator HON 380 labels and markings

The labels and markings of the gas pressure regulator can be found here:

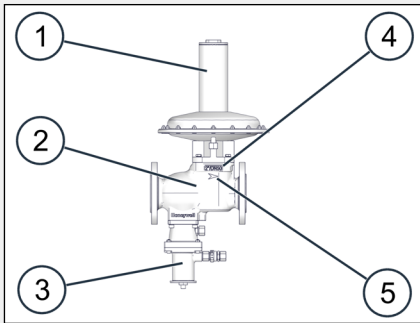
Figure	No.	Description
	1	Regulator type plate
	2	Gas pressure regulator type plate
	3	Arrow indicating direction of flow on controller type plate
	4	Body nominal size
	5	Arrow indicating the direction of flow

Nameplates

For the location of the nameplates, as well as a detailed list of the information on them and what it means, please refer to:

Identifying the device (see page 10)

Labels on connection lines

Small labels must be used to color-code and explicitly name the gas pressure regulator’s connection lines (measuring lines and operating lines) based on what the lines are intended for and their minimum nominal size.

2.4 Identifying the device

Identifying the gas pressure regulator

Make sure you have the right manual for your gas pressure regulator.
Use the nameplates to identify the gas pressure regulator.

Verifying the technical specifications

Make sure that the on-site conditions match the information on the nameplates and the technical specifications.

Technical specifications

Locating the gas pressure regulator's nameplates

The gas pressure regulator HON 380 type plate locations are as follows:

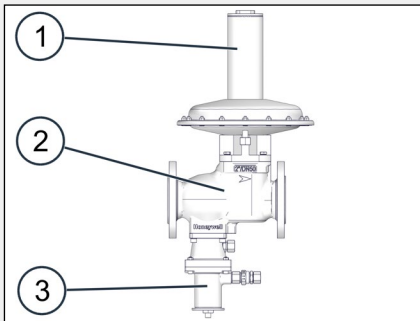
Figure	No.	Meaning
	1	Front of the body
	2	On the side of the regulator unit
	3	On the side of the controller

Interpreting the type plate of the gas pressure regulator

The details on the type plate have the following meaning:

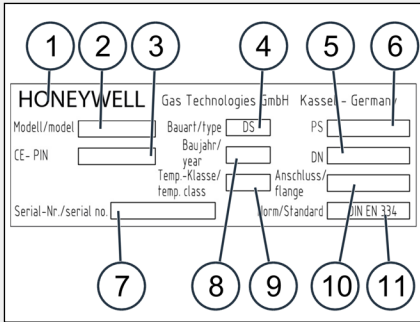
Figure	No.	Meaning
	1	Manufacturer
	2	Model name
	3	CE - PIN
	4	Device version
	5	Nominal size
	6	PS = Maximum allowable pressure
	7	Serial number of the device
	8	Year built
	9	Temperature range
	10	Connection
	11	Standard (EN 334)

Interpreting the type plate on the regulator unit

The details on the type plate have the following meaning:

Figure	No.	Meaning
	1	Manufacturer
	2	Model name
	3	maximum inlet pressure
	4	Serial number of the device
	5	Failure function (fail-open)
	6	W_{ds} = specific setpoint range
	7	Serial number of the device
	8	PSD = maximum permissible outlet pressure
	9	P_{ds} = nominal value of the controlled variable
	10	Valve seat diameter

Interpreting the type plate and additional type plate of the controller

The type plates are described in the HON 673 / HON 674 component documentation.

2.5 Physical design and operation

Figure

The gas pressure regulator is made up of the following assemblies:

Figure	No.	Description
	1	Regulator unit (RE):
	2	Body
	3	Controller - safety shut-off valve (SAV)

Design of the regulator unit RE1 DN 50

Design of the regulator unit:

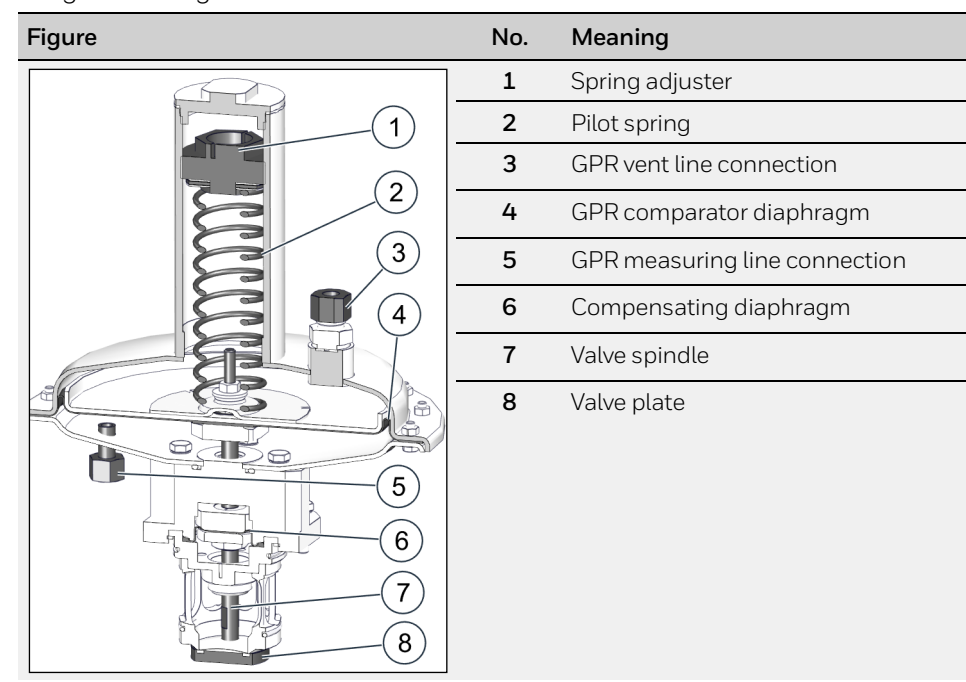

Design of regulator unit RE2

Design of the regulator unit:

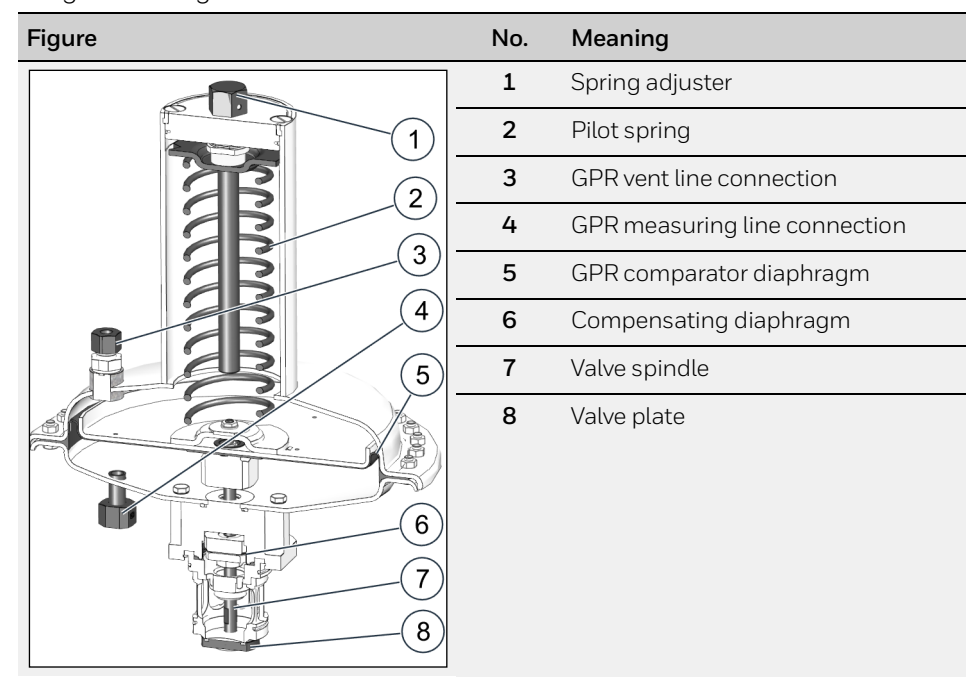

Design of regulator unit REO

Design of the regulator unit:

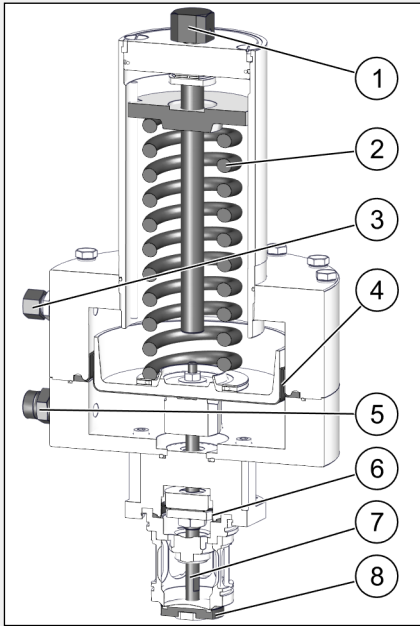
Figure	No.	Meaning
	1	Spring adjuster
	2	Pilot spring
	3	GPR vent line connection
	4	GPR comparator diaphragm
	5	GPR measuring line connection
	6	Compensating diaphragm
	7	Valve spindle
	8	Valve plate

Design of the controller

The design of the controller is described in the component documentation included in delivery.

Connection lines of the HON 380 gas pressure regulator

Connections of the gas pressure regulator:

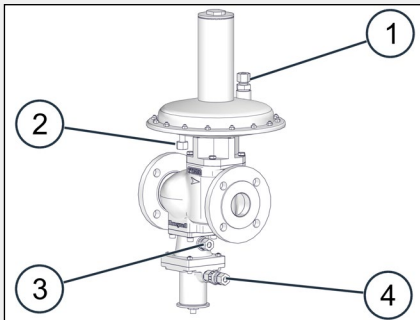
Figure	No.	Connection
	1	Vent line connection, regulator unit
	2	Measuring line connection, regulator unit
	3	Measuring line connection, SAV
	4	Vent line connection, SAV

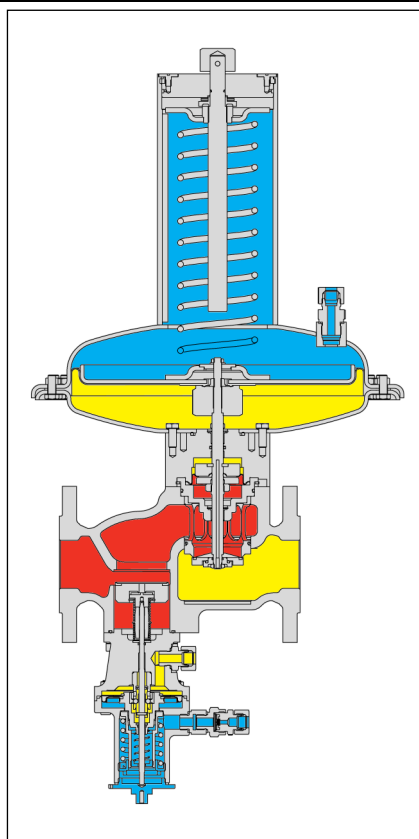

Functional diagram of the HON 380 gas pressure regulator

Figure



Color

Meaning

	Outlet pressure
	Atmospheric pressure
	Inlet pressure

How the HON 380 gas pressure regulator works

- The comparator diaphragm of the regulator unit captures the actual value of the outlet pressure and compares it with the reference variable specified by the pilot spring.
 - A regulation deviation directly influences the closing member position via the valve spindle. The flow rate change this causes results in an adjustment of the outlet pressure actual value so that it matches the setpoint. When there is zero pressure flow, the device seals tightly.
- If the actual value of the outlet pressure in the regulating line exceeds or falls below a certain response pressure, the closing member of the safety shut-off valve located on the input side shuts off the flow of gas.
 - The SAV measuring diaphragm with the switching sleeve moves into the corresponding disengaged position, the ball engagement mechanism enables the SAV valve spindle and the control element of the safety shut-off closes.
- The SAV can only be engaged in the open position manually when the outlet pressure at the sensing point is at least within the specified re-engage differential range for overpressure or underpressure relative to the response pressure setpoint.
- The SAV can also be equipped with a manual or a remote release feature, as desired. It is also possible for it to be executed in functional class A (with diaphragm rupture protection) or B (without diaphragm rupture protection).

2.6 Technical specifications

Materials

Components	Material
Valve body	Cast steel
SAV	Aluminum cast alloy and aluminum wrought alloy
Casing of actuator	Steel plate / aluminum alloy
Diaphragms; gaskets	NBR
Internal parts	Aluminum alloy, steel, brass

Environmental conditions

Criterion	Value
Max. inlet pressure p_{umax}	20 bar
Temperature range	-20 to +60 °C (-4 to +140 °F)

Pressure rating and flange facing standards

There are various flange facings for the nominal diameters of 1" (DN 25), 2" (DN 50), 3" (DN 80), and 4" (DN 100) as specified in the following standards:

- **ASME B16.5**
Pressure rating as per Class 150 = 20 bar
Flange facing: Raised face
- **DIN EN 1092-1**
Pressure rating as per PN 16 = 16 bar
Flange facing: B flange

HON 380 dimensions

The figures show schematic representations of the device's structure. The dimensions for the different types can be taken from the table.

Type DN 25 and DN 50

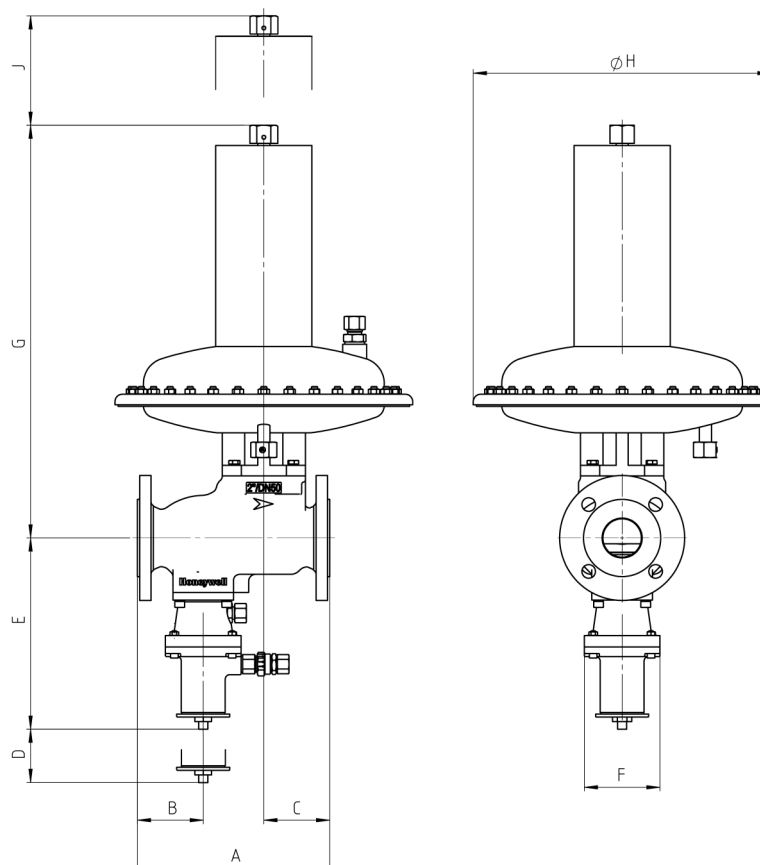

Type DN 80 and DN 100

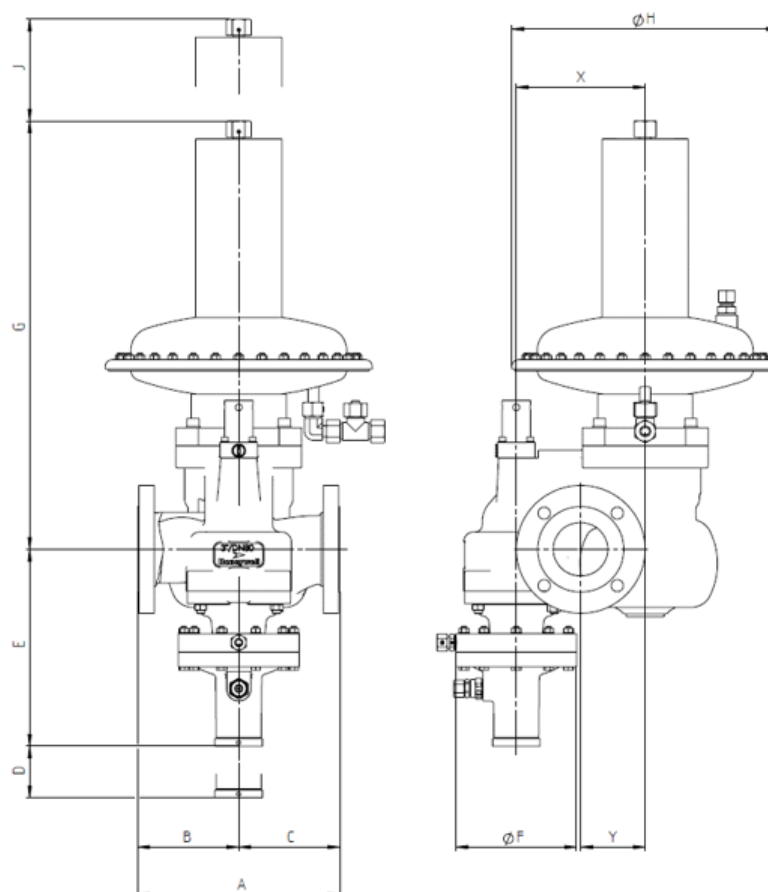

Size	Valve body			Safety shut-off valve				
	A mm (in.)	B mm (in.)	C mm (in.)	X mm (in.)	Y mm (in.)	D mm (in.)	E mm (in.)	ØF mm (in.)
DN 25 (1")	184 (7.24)	64 (2.52)	72 (2.83)			75 (2.95)	255 (10.04)	105 (4.13)
DN 50 (2")	254 (10.00)	87 (3.43)	87 (3.43)			80 (3.15)	255 (10.04)	105 (4.13)
DN 80 (3")	298 (11.73)	149 (5.87)	149 (5.87)	190 (7.48)	95 (3.74)	250 (9.84)	300 (11.81)	max. 180 (7.09)
DN 100 (4")	352 (13.86)	185 (7.28)	164 (6.46)	225 (8.86)	110 (4.33)	300 (11.81)	310 (12.20)	max. 180 (7.09)

Size	Gas pressure regulator with regulator unit								
	RE1			RE2			RE0		
	G mm (in.)	ØH mm (in.)	J mm (in.)	G mm (in.)	ØH mm (in.)	J mm (in.)	G mm (in.)	ØH mm (in.)	J mm (in.)
DN 25 (1")	405 (15.94)	297 (11.69)	105 (4.13)				525 (20.67)		105 (4.13)
DN 50 (2")	410 (16.14)		110 (4.33)	550 (21.65)	395 (15.55)	110 (4.33)	525 (20.67)	250 (9.84)	110 (4.33)

Gas pressure regulator with regulator unit									
RE1			RE2			RE0			
Size	G mm (in.)	ØH mm (in.)	J mm (in.)	G mm (in.)	ØH mm (in.)	J mm (in.)	G mm (in.)	ØH mm (in.)	J mm (in.)
DN 80 (3")				640 (25.20)		200 (7.87)	620 (24.41)		200 (7.87)
DN 100 (4")				630 (24.80)		205 (8.07)	610 (24.02)		205 (8.07)

HON 380 weights

Gas pressure regulator with regulator unit						
RE1		RE2		RE0		
	with SAV	without SAV	with SAV	without SAV	with SAV	without SAV
Size	kg (lb)	kg (lb)	kg (lb)	kg (lb)	kg (lb)	kg (lb)
DN 25 (1")	18 (40)	16 (35)			34 (75)	32 (71)
DN 50 (2")	24 (53)	22 (49)	35 (77)	33 (73)	41 (90)	38 (84)
DN 80 (3")			73 (161)	65 (143)	79 (174)	71 (157)
DN 100 (4")			89 (196)	80 (176)	95 (209)	85 (187)

Connections of the lines

Controller		SAV	
Measuring line		Vent line	Measuring and breather lines
Connection for			
RE1	Pipe 12 x 1.5 (pipe 12 x 1.5 on the device)	Pipe 12 x 1.5 (thread G 1/2)	
RE2	Pipe 16 x 2 (pipe 16 x 2 on the device)	Pipe 12 x 1.5 (thread G 1/2)	Pipe 12 x 1.5 (thread G 3/8)
RE0	Pipe 16 x 2 (thread G 1/2)	Pipe 12 x 1.5 (thread G 3/8)	

Operating pressure, Class 150

Criterion	Value
Nominal diameter	DN 25 (1"), DN 50 (2"), DN 80 (3"), DN 100 (4")
Maximum operating pressure	20 bar (285 psi)

Operating pressure, PN 16

Criterion	Value
Nominal diameter	DN 25 (1"), DN 50 (2"), DN 80 (3"), DN 100 (4")
Maximum operating pressure	16 bar (232 psi)

ATEX specifications

The device's mechanical components do not contain any potential sources of ignition, and accordingly do not fall under the scope of ATEX 95 (94/9/EC). The electrical components used on the device meet all applicable ATEX requirements.

3 Safety

Contents

Topic	Page
Basic safety rules	19
Requirements concerning the workforce, personal protective gear, workplaces	20

3.1 Basic safety rules

Target group of these rules	These rules are intended for any individuals handling the device.
Purpose of these rules	These rules are designed to make sure that any individuals handling the device obtain detailed information about the dangers and safety procedures and observe the safety notices contained in the user manual and on the device. If you do not follow these rules, there is a risk of injury including death and material damages.
Handling the user manual	<p>Observe the following rules:</p> <ul style="list-style-type: none"> ▪ Read the chapter entitled Safety and the chapters relating to your responsibilities in their entirety. It is vital that you have understood these contents. ▪ Always keep the user manual close by the device so that you can refer to it again. ▪ Include the user manual if you are giving the device away.
Handling the device	<p>Observe the following rules:</p> <ul style="list-style-type: none"> ▪ Only individuals who meet the requirements set forth in this user manual have permission to handle the device. ▪ The device's intended use includes its use in hazardous locations. All work with and on the device must be carried out only after the presence of an explosive atmosphere has been fully ruled out. ▪ Only use the device for the intended purpose. Never use the device for any other, potentially logical purposes. ▪ Follow all safety procedures outlined in this user manual and on the device. In particular, wear the mandatory personal protective gear. ▪ Only stay at the specified work places. ▪ Do not modify the device in any way, e. g. by removing parts or adding unapproved parts. In particular, you have no permission to modify or disable any safety contrivances. ▪ Adhere to the device maintenance intervals specified in this user manual. ▪ When replacing defective parts, only use original spare parts or manufacturer-approved standard parts.

Operator’s duties opposite the employees

In your capacity as the company operating the device, you must ensure the following:

- All personnel must meet the requirements corresponding to their duties.
- All personnel must read and understand this user manual before working with/on the device.
- All occupational health and safety regulations that apply in your country must be complied with.
- Hazards resulting from specific working conditions at the location where the device is being used must be determined by means of a risk assessment and rendered avoidable by means of appropriate operating instructions.
- All personnel must be provided with the personal protective equipment required for their work. This personal protective equipment must be in good condition at all times.
- All personnel must wear the personal protective equipment required for their work.

Conduct in the event of accidents

The device is designed and built such that the employees can work with it without being at risk. In spite of all the precautions, accidents can happen under unfavorable circumstances. Always consult the directives of your company concerning the protection of the workforce.

3.2 Requirements concerning the workforce, personal protective gear, workplaces

Requirements concerning the workforce

Individuals tasked with handling the device must meet the following requirements:

Personnel	Responsibilities	Required qualification
Skilled person or expert	Any work on and with the device	<ul style="list-style-type: none"> ▪ Professional training and experience operating pressure equipment and systems ▪ Knowledge of the relevant standards and regulations ▪ Ability to identify and avoid dangers autonomously
Certified, independent competent person	Safety checks	<ul style="list-style-type: none"> ▪ Professional training ▪ Knowledge of the relevant standards and regulations ▪ Ability to identify and avoid dangers autonomously
Carrier	Company-to-company transport	<ul style="list-style-type: none"> ▪ Professional training and experience transporting pressure equipment and systems ▪ Knowledge of the relevant standards and regulations ▪ Ability to identify and avoid dangers autonomously ▪ Knowledge with securing hauling distances ▪ Knowledge with the use of hoisting equipment
Transportation personnel	Intra-company transport	Professional training and experience with the transport using stackers, etc.

Personnel	Responsibilities	Required qualification
Mechanics	Mechanical installation	<ul style="list-style-type: none"> ▪ Professional training and experience operating pressure equipment and systems ▪ Knowledge of the relevant standards and regulations ▪ Ability to identify and avoid dangers autonomously
Tasked with the commissioning	<ul style="list-style-type: none"> ▪ Initial start-up ▪ Renewed start-up 	<ul style="list-style-type: none"> ▪ Professional training and experience operating pressure equipment and systems ▪ Knowledge of the relevant standards and regulations ▪ Ability to identify and avoid dangers autonomously
Tasked with the installation	Set-up	<ul style="list-style-type: none"> ▪ Professional training and experience operating pressure equipment and systems ▪ Knowledge of the relevant standards and regulations ▪ Ability to identify and avoid dangers autonomously
Mechanical maintenance personnel	Involving mechanical parts: <ul style="list-style-type: none"> ▪ Troubleshooting ▪ Maintenance ▪ Repairs 	<ul style="list-style-type: none"> ▪ Professional training and experience operating pressure equipment and systems ▪ Knowledge of the relevant standards and regulations ▪ Ability to identify and avoid dangers autonomously
Inspector	Safety check	Qualified inspector with adequate knowledge of gas pressure regulators
Tasked with the disposal	Disposal of the device	<ul style="list-style-type: none"> ▪ Professional training and experience with the disposal of pressure equipment and systems ▪ Knowledge of the relevant standards and regulations ▪ Ability to identify and avoid dangers autonomously

Requirements for the personal protective gear

Any persons handling the device must be equipped with the following personal protective gear:

Task	Required personal protective gear
Start-up, operation (including partial), cleaning, maintenance, search and remedy of errors	<ul style="list-style-type: none"> ▪ Industrial protective helmet ▪ Protective clothing ▪ Safety harness ▪ Ear protection ▪ Safety boots with protection for electrostatic discharge (ESD) ▪ Safety goggles ▪ Safety gloves

Workplace requirements

To ensure the safe handling of the device, the personnel must remain at the workplaces intended for performing their tasks.

The workplaces for performing the various tasks are at the following locations:

Task	Workplaces
<ul style="list-style-type: none"> ▪ Installation ▪ Start-up ▪ Set-up ▪ Maintenance, repairs ▪ Decommissioning 	All around the device, depending on the task

4 Basics for installing the device in a pipe

Contents

Topic	Page
Installation example	23
Meter run characteristics	24
Operating and measuring lines	26

4.1 Installation example

Gas pressure regulating line – example

Configuration:

- Direct acting gas pressure regulator (non-piloted)
- With expander without noise reduction element downstream of the gas pressure regulator

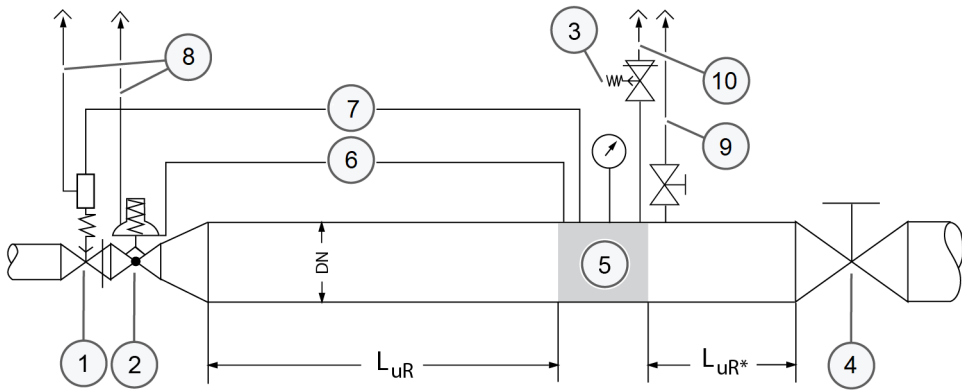

Legend

The numbers have the following meaning:

No.	Meaning
1	Safety Shut-Off Valve
2	Gas pressure regulator
3	Safety relief valve
4	Outlet stop valve armature
5	Sensing point for connection lines (gray area)
6	Gas pressure regulator measuring line
7	Slam-shut device measuring line
8	Vent line
9	Relief line
10	Blowdown line

Following is the meaning of the acronyms:

Acr.	Meaning
DN	Nominal size of pipe
L _{uR}	Undisturbed length of pipe

* Shut-off device with undisturbed flow pattern (ball valve) can be incorporated

4.2 Meter run characteristics

Standards used as a basis

The following recommendations are based on the measuring line connection conditions set forth in standards (DIN) EN 334 and (DIN) EN 14382. The company operating the system is the sole party responsible for the meter run working properly.

Conditions for the meter run

- A pipe area with a steady flow pattern must be selected for the sensing point. There must not be any components that disturb the flow directly upstream and downstream of the sensing point, e.g., orifice plates, expanders, bends, junctions, shut-off devices, etc.
- The flow rate at the sensing point should not exceed approx. 25 m/s, depending on the system conditions.
- In the case of specific system circuits (such as gas regulating lines for gas engines) and in the case of gas burners, flow rates higher than 25 m/s may be allowed following consultation with the manufacturer.
- Within a low-pressure range of up to approx. 250 mbar, a maximum flow rate of approx. 15 to 20 m/s is recommended at the sensing point. On a case-by-case basis, and following consultation with the manufacturer, even lower flow rates may be allowed.

Upstream of the sensing point

Depending on the specific system design, the L_{UR} lengths of the undisturbed pipes upstream of the sensing point must be $(2.5 \text{ to } 5) \times \text{DN}$ of the pipe, with the specifics depending on the gas pressure regulator model and whether or not there is a pipe expander downstream:

If ...	and...	then...
A gas pressure regulator with an expander that is part of the device is used	The nominal size of the pipe is equal to the outlet-side nominal size of the gas pressure regulator	$L_{UR} \text{ min. } 2.5 \times \text{DN}$
	The nominal size of the pipe is the next larger standard nominal size	$L_{UR} \text{ min. } 3 \times \text{DN}$
	The nominal size of the pipe is two standard nominal size increments larger	$L_{UR} \text{ min. } 4 \times \text{DN}$
	The nominal size of the pipe is more than two standard nominal size increments larger	$L_{UR} \text{ min. } 5 \times \text{DN}$
A gas pressure regulator with the same outlet nominal size as the inlet nominal size is used	The nominal size of the pipe is the next larger standard nominal size	$L_{UR} \text{ min. } 4 \times \text{DN}$
	The nominal size of the pipe is two standard nominal size increments larger	$L_{UR} \text{ min. } 5 \times \text{DN}$

Downstream of the sensing point

Depending on the specific system design, the L_{UR} lengths of the undisturbed pipes downstream of the sensing point must be $(1.5 \text{ to } 4) \times \text{DN}$ of the pipe:

Undisturbed length of pipe	for
$L_{UR} \text{ min. } 1.5 \times \text{DN}$	Thermowells
$L_{UR} \text{ min. } 1.5 \times \text{DN}$	Reducers and expanders, depending on the specific system conditions
$L_{UR} \text{ min. } 3 \times \text{DN}$	Shut-off devices (gate valves, check valves, and reduced bore ball valves)
$L_{UR} \text{ min. } 4 \times \text{DN}$	Tees

Details

- Shut-off devices with an undisturbed flow pattern (such as full bore ball valves) and, if applicable, pipe bends (depending on the design) are considered to be non-disturbing elements in terms of measuring line connections.
- For gas meters (turbine gas meters including quantometers, ultrasonic gas meters, and vortex flow meters, but NOT rotary piston gas meters), there are no restrictions in terms of measuring line configurations, as these meters are not considered to be flow-disturbing within this context.
- The following applies to rotary piston gas meters: Minimum distance between gas pressure regulator or reducer / expander and gas meter:
 $L_{UR} \text{ min. } 3 \times \text{DN}$.
- Measuring line connections downstream of gas meters must be at a distance of **$L_{UR} \text{ min. } 2 \times \text{DN}$.**
- If shut-off valves are used (reduced bore), the recommended distance downstream of a measuring line is **$L_{UR} \text{ min. } 3 \times \text{DN}$.**
- Gas meter pressure losses must be taken into account based on system conditions if applicable.

4.3 Operating and measuring lines

Connection lines between device and gas regulating line

The lines must be arranged and sized in such a way that the devices' intended function will be ensured.

- **Measuring line**
 - The measuring line transmits the pressure process value from the sensing point to the measuring diaphragm of a controller or the pilot of a gas pressure regulator or safety relief valve or to the measuring diaphragm of the monitoring device of a slam-shut device. It needs to be connected to the pipe sideways or upwards separately for each device. In the case of safety equipment, the measuring line must be connected upstream of the first outlet-side shut-off device in such a way that it cannot be shut off. If the measuring line is additionally connected downstream of the first outlet-side shut-off device, 3-way ball valves with negative overlap must be used for switching. These ball valves do not have a valve position in which both measuring lines can be fully closed at the same time.
 - **Vent line**
 - The vent line is used to connect a measuring diaphragm to the atmosphere. If the measuring unit becomes damaged (e.g., diaphragm rupture), it can start conveying gas. Under certain operating conditions, and following consultation with the manufacturer, vent lines can be omitted if vent valves (HON 915) or safety diaphragm configurations can be used instead.
 - **Blowdown line**
 - The blowdown line in a safety relief valve is used to divert gas (leaking gas, for example) into the atmosphere.
 - Grouping vent lines or blowdown lines (into a header) is permissible if it does not have a negative impact on the individual devices' operation. Within this context, it is recommended to have the cross-sectional area of the header be at least five times as large as the total of the individual lines' cross-sectional areas.
 - For primary slam-shut devices, it is recommended to route the slam-shut devices' vent lines separately. Vent lines must not be grouped together with blowdown lines.
 - **Discharging line**
 - When using indirect acting (pilot-operated) slam-shut devices, the discharging line is used to divert the exhaust gas from the pilot into the system's outlet chamber. On certain devices, the discharging line will be grouped with the feedback line.
 - **Feedback line**
 - When using indirect acting (pilot-operated) slam-shut devices, the feedback line is used to return the outlet pressure to the actuator.
-

5 Transport and installation

Contents

Topic	Page
Transporting the gas pressure regulator	27
Installing the gas pressure regulator	28
Installing the device connections	30
Checking the system for leaks	31

5.1 Transporting the gas pressure regulator

Heavy transport units



Risk of serious injury posed by heavy loads when using cranes for transportation

Transporting heavy devices or components with a crane may result in serious impact and crush injuries if the loads start moving in an uncontrolled manner.

- ⇒ Loads may only be transported with a crane by a duly qualified person.
- ⇒ Markings and information about the center of gravity of the load (if applicable) must be observed.
- ⇒ Loads may only be moved under supervision.

Suspended loads



Risk of serious injury in the event that load handling attachments break while holding a suspended load

Heavy loads picked up or transported with hoisting and slinging gear may result in serious impact and crush injuries if the load handling attachments fail.

- ⇒ Only fasten the device at the positions intended for the transport.
- ⇒ The load-bearing capacity of the appropriate hoisting equipment must correspond at least to the weight of the load to be transported.
- ⇒ Always stand clear of suspended loads.
- ⇒ Ensure that no person is within the danger zone.

Selecting the hoisting equipment and slings

A mobile workshop crane is suitable for use as hoisting equipment. A pallet jack or forklift is also suitable for intraplant transportation.

The following are adequate for use as slings:

- Ropes
- Belts
- Chains

The hoisting equipment and slings must meet the following criteria:

- The load capacity must be sufficient for the gas pressure regulator's weight.
- The hoisting height is adequate for the mounting position at the installation site.

Preparing for transportation

Make sure that the following requirements are met before transportation:

- You have seen and taken into account all instructions on the packaging regarding the orientation of the packed device, the center of gravity, and attachment points.
- The transport route is clear of obstacles and other barriers, and there is enough space available for the dimensions of the packed device and the handling equipment. Make sure to measure all of the package's dimensions!
- The transport route will be able to handle the load exerted by the total weight of the handling equipment and the load being transported.
- There is enough space for unpacking and installing the device at the installation location.

Transporting the device

Proceed as follows:

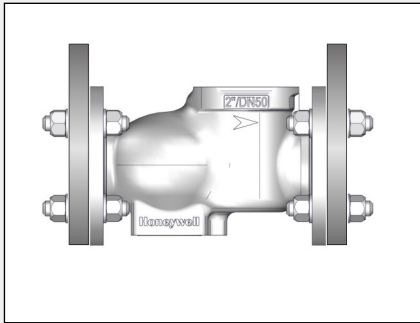
Figure	Step	Description
	1	Leave the transport panels on the HON 380 during transport.
	2	Lift the HON 380. Slowly and carefully transport the HON 380 to the location where it will be installed.

5.2 Installing the gas pressure regulator

Preparing the materials

Prepare the following materials:

- Flange gaskets
- Screws
- Washers
- Nuts

The quantity and size are dependent on the following criteria:

- Design and size of the flange

Assessing the situation

Assess the installation situation.

The numbers have the following meaning:

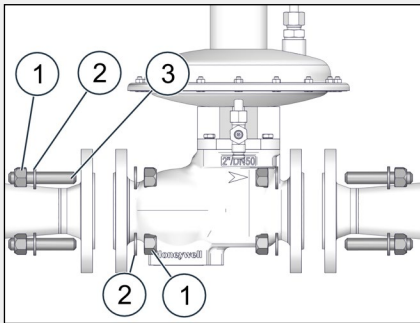
Figure	No.	Meaning
	-	Flange gasket (not shown)
	1	Nut
	2	Washer
	3	Screws

Installing the gas pressure regulator

Proceed as follows:

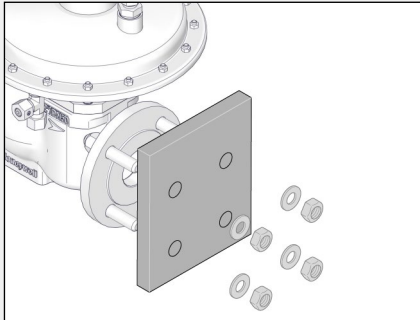
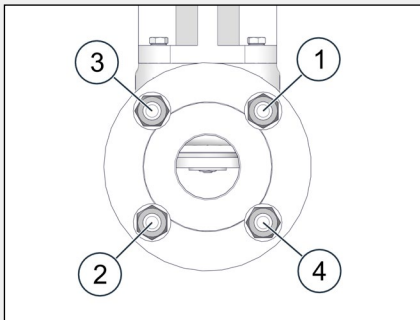
Figure	Step	Description
	1	Remove the transport panels.
	2	Transport the device to the location where it will be installed. <ul style="list-style-type: none"> ▪ The device needs to be installed in the piping in a horizontal and level position. If you want to use a different installation position, consult with the manufacturer first. ▪ Pay attention to the direction of flow for the gaseous fluid as marked on the body.
	3	Secure and support the device's position in such a way that the device can be installed in the piping without any stress and that the piping's weight will be supported as well.
	4	Install the flange gaskets.
	5	Screw down the flange crosswise in the specified order. When doing so, make sure to observe the torques specified by the flange gaskets' manufacturer.

Final inspection

Conduct a final inspection to check whether the following criteria are met:

- All screwed connections on the device and supply lines are securely fastened.

If ...	then ...
at least one criterion is not met	you should correct the error before proceeding with the next task.
all criteria are met	you may proceed with the next task.

Next task

Proceed as follows:

Installing the device connections (see page 30)

5.3 Installing the device connections

HON 380 operating and measuring lines to be installed

The operating and measuring lines to be installed can be found here:

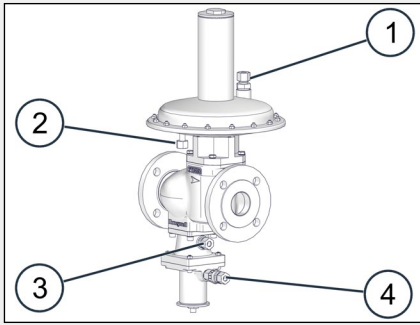
Figure	No.	Designation, category, installation condition
	1	Controller: Vent line, operating line,
	2	Controller: Outlet pressure measuring line
	3	SAV: Outlet pressure measuring line
	4	SAV: Vent line, Operating line

Preparing the materials

Prepare the following materials:

- Pipes, connecting pieces, and fittings as per the specifications in the *Technical specifications*
- Shut-off devices for the operating and measuring lines, as well as other accessories, as required, as per the *Basics for installing the device in a pipe* (see page 23) section.

Installing the operating and measuring lines

The installation of the operating and measuring lines depends on the local conditions and the gas regulating line in which the gas pressure regulator is being used. Please refer to the *Basics for installing the device in a pipe* (see page 23) section for more information on what needs to be ensured without fail in the corresponding design and implementation.

Final checks

Conduct a final inspection to check whether the following criteria are met:

- All threaded joints on the connection lines have been checked to ensure that they have a secure fit.

If ...	then ...
at least one criterion is not met	you should correct the error before proceeding with the next task.
all criteria are met	you may proceed with the next task.

Next task

Proceed as follows:

Checking the system for leaks (see page 31)

5.4 Checking the system for leaks

Leak test conducted by the manufacturer

Prior to delivery, the manufacturer conducted a pressure and leak test on the gas pressure regulator as specified in DIN EN 334.

Leak test at the set-up location (in Germany)

The gas pressure regulator installed in the system must be subjected to a leak test at the setup location as follows:

Normative basis	DVGW Technical Rule G 491
Test method	Bubble test method
Test medium	Air or inert gas
Scope of the test	All detachable pipe joints
Test equipment	Foam-generating leakage medium
Test pressure	1.1 times the operating pressure (MOP)

Leak test at the set-up location (in other countries)

The device installed into the system must undergo a leak test at the set-up location in accordance with applicable international and national standards.

Pressurized parts

⚠ WARNING

Risk of serious injury posed by pressurized components moving in an uncontrolled manner when handled improperly.

If not handled properly or in the event of a defect, gas can escape from pressurized components under high pressure and cause serious injuries and even death. Before you start working on these components:

- ⇒ Close all connections leading to the gas-carrying line.
- ⇒ Establish a depressurized status. Residual amounts of energy must be depressurized as well.

Pressurized parts

⚠ WARNING

Risk of injury posed by bursting parts in the event that they are subjected to pressure in the wrong direction

The device has been designed for a specific direction of flow, which is labeled on the device. Subjecting the device to pressure in the wrong direction may result in serious injury caused by bursting parts.

- ⇒ Pressurize the system only on the inlet side.

Details about the operating pressure can be found in the technical specifications.
Technical specifications

Test configuration

The test setup is as follows (schematic diagram, using the RE1 DN50 and HON 673 as a reference):

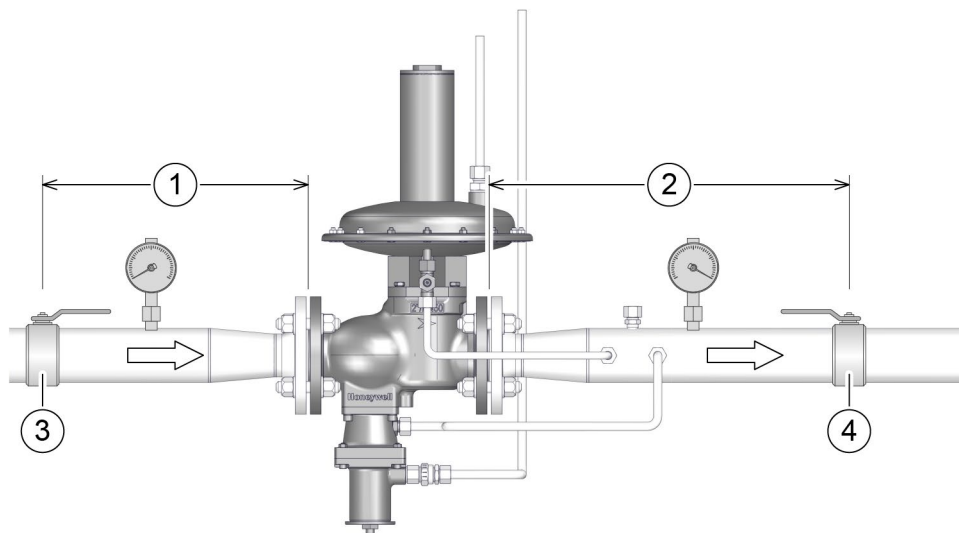

The numbers have the following meaning:

No.	Meaning
1	Inlet chamber
2	Outlet chamber
3	Inlet stop valve armature
4	Outlet stop valve armature

Checking the system for leaks

Proceed as follows:

Step	Description
1	Slowly close the outlet stop valve armature.
2	Apply the test medium to all detachable pipe joints.
3	Observe the test medium on all detachable pipe joints for several minutes.

If ...	then ...
no foam or bubbles are formed	<ul style="list-style-type: none"> ▪ the system is leak-proof. ▪ the system may be put into operation.
foam or bubbles are formed	<ul style="list-style-type: none"> ▪ the affected pipe joint is leaking. ▪ the system may not be put into operation. ▪ Proceed with step 4.

Step	Description
4	Slowly close the inlet stop valve armature.
5	Depressurize the inlet chamber and the outlet chamber.
6	Seal the leaking pipe joints.
7	Repeat the leak test starting with step 1.

6 Adjusting the settings of the device

Contents

Topic	Page
Adjusting the regulator unit setpoint	33
Adjusting the throttle valve on the measuring line of the regulator unit	36

6.1 Adjusting the regulator unit setpoint

Requirements

Make sure that the following requirements are met:

- Apply the inlet pressure slowly because the device is open when in the pressureless state.
- The inlet and outlet shut-off devices for the gas regulating line section with the gas pressure regulator are closed.
- The pressure in the outlet chamber downstream of the gas pressure regulator is lower than the setpoint for outlet pressure p_d .
- The shut-off devices for the blowdown lines are closed.
- The inlet pressure is present upstream of the inlet shut-off device.

Pilot spring of the regulator unit

Specific setpoint range W_{ds} [mbar]	Compression spring						
	RE0		RE1		RE2		
	Part no.	Wire diameter [mm]	Part no.	Wire diameter [mm]	Part no.	Wire diameter [mm]	Color
20 - 30			10007241	3.6	15056070	5	Signal blue
25 - 50			10003629	4	10009068	6.3	grey
45 - 75			15055022	4.5	15056072	7	Gentian blue
70 - 100			10003630	4.5	10009069	7	Yellow
90 - 160			15055023	5.3	15056073	8	Fire red
150 - 200			10003631	5.3	10009070	8	brown
190 - 260			15055024	6.3	15056074	9	Nut brown
250 - 300			10003632	6.3	15056075	9	Light red
290 - 360			15055025	7	15056076	10	Rapeseed yellow
350 - 400			10003633	7	10009072	10	Dark red
390 - 500			15055026	7.5	10009073	11	light blue
490 - 560			15055027	8.5	15056077	11	Rapeseed yellow
550 - 660			15055028	9	15056078	12	Cream white
650 - 760			15055029	9.5	15056079	12	Gentian blue
750 - 800			10012564	9.5	10009164	13	Emerald green
790 - 900			15055030	10	15056081	13	Fire red
890 - 1000			15055031	10	10009165	14	black

Specific setpoint range W_{ds} [mbar]	Compression spring						
	RE0		RE1		RE2		
	Part no.	Wire diameter [mm]	Part no.	Wire diameter [mm]	Part no.	Wire diameter [mm]	Color
1000 - 2000	10009163	12					White
1500 - 2000	10009164	13					Green

Adjusting the control stage setpoint

Proceed as follows:

Figure	Step	Description
 <p>*RE1</p>	1	Remove the cap (1) of the diaphragm housing. *) Only for RE1 versions.
	2	Open the inlet shut-off device.
 <p>*RE1</p>	3	*) Turn the spring adjuster in small increments until the pressure gauge in the outlet chamber shows the set-point for the correct outlet pressure p_d . Turn the spring adjuster <ul style="list-style-type: none"> ▪ Clockwise (+) to tighten the pilot spring or <ul style="list-style-type: none"> ▪ Counterclockwise (-) to loosen the pilot spring
 <p>**RE2 and RE0</p>		**) Turn the spring adjuster in small increments until the pressure gauge in the outlet chamber shows the set-point for the correct outlet pressure p_d . Turn the spring adjuster <ul style="list-style-type: none"> ▪ Clockwise (+) to tighten the pilot spring or <ul style="list-style-type: none"> ▪ Counterclockwise (-) to loosen the pilot spring

Figure	Step	Description
	4	<p>Open the outlet shut-off device. Wait a few minutes and check the reading for outlet pressure p_d in the outlet chamber.</p> <p>If necessary, keep adjusting the setting of the spring adjuster until you get the right outlet pressure p_d.</p>
	5	<p>Put the cap (1) back onto the diaphragm housing.</p> <p>*) Only for RE1 versions</p>

*) RE1

6.2 Adjusting the throttle valve on the measuring line of the regulator unit

Changes in control behavior achieved by adjusting the throttle valve

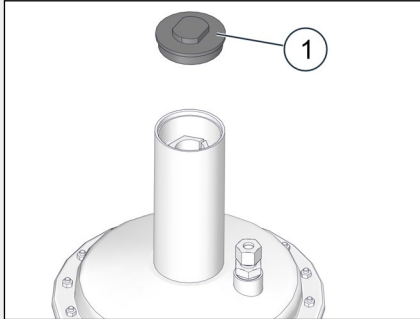
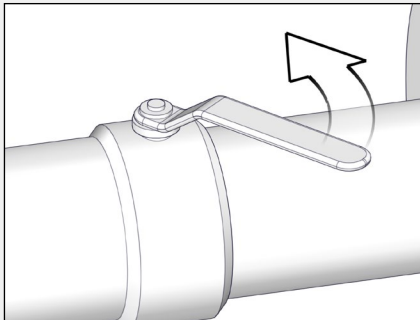
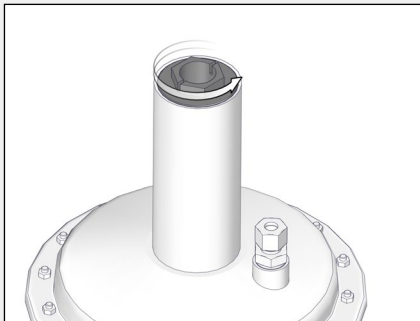
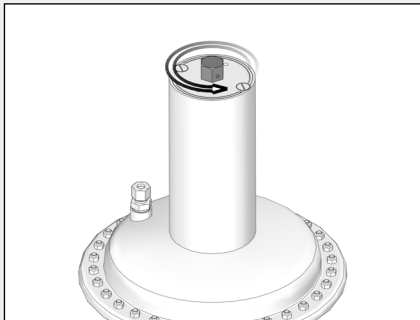
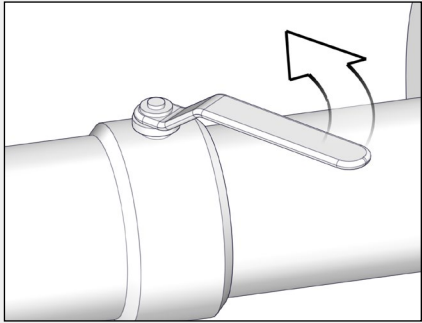
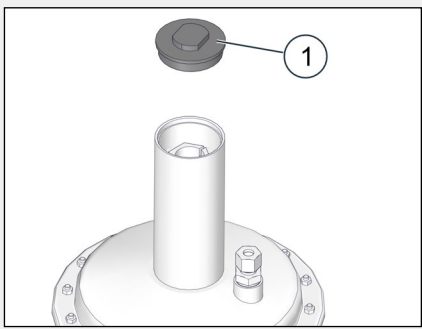
The following changes in the gas pressure regulator's control behavior can be achieved by adjusting the throttle valve on the regulator unit:

- If the gas pressure regulator exhibits sluggish control behavior, the response times can be shortened.
- If the gas pressure regulator's dynamic control behavior is too fast and this results in oscillations, the regulator unit's reaction can be slowed down.
- Additional information on control behavior changes can be found in the *HON General user manual*.

Setting the throttle valve

If you want to **speed up the regulator unit's response behavior**, follow the steps below:

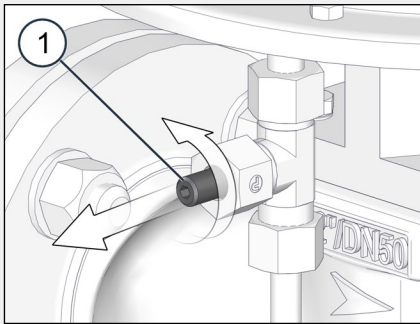
Figure	Step	Description
	1	Unscrew the spacer nut a bit.
	2	Use an Allen wrench to screw the spindle (1) out turn by turn while monitoring the regulator unit's control behavior. Once you achieve the regulator unit response you want, stop changing the spindle's position.
	3	Tighten the spacer nut.

If you want to **slow down the regulator unit's response behavior**, e.g., in the case that there are oscillations, follow the steps below:

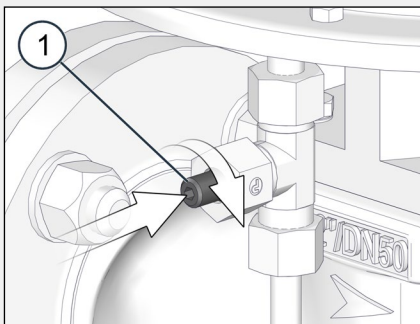
Figure	Step	Description
	1	Unscrew the spacer nut a bit.
	2	Use an Allen wrench to screw the spindle (1) further in turn by turn while monitoring the regulator unit's control behavior. Once you achieve the regulator unit response you want, stop changing the spindle's position.
	3	Tighten the spacer nut.

7 Malfunctions

Contents

Topic	Page
Malfunctions	37

7.1 Malfunctions

Pressurized parts



Risk of serious injury posed by pressurized components moving in an uncontrolled manner when handled improperly.

If not handled properly or in the event of a defect, gas can escape from pressurized components under high pressure and cause serious injuries and even death. Before you start working on these components:

- ⇒ Close all connections leading to the gas-carrying line.
- ⇒ Establish a depressurized status. Residual amounts of energy must be depressurized as well.

Malfunctions and abnormalities

The following table contains a description of malfunctions and abnormalities that may occur during the operation and lists procedures to correct them:

Malfunction	Possible causes	Correction
Regulator unit does not open	Regulator unit malfunction	<i>Performing maintenance on regulator unit (see page 47)</i>
The regulator unit will not close	Faulty regulator unit	<i>Performing maintenance on regulator unit (see page 47)</i>
The regulator unit is opening/closing too slowly	The regulator's control speed is not correct	Regulating the regulator's control speed, <i>Adjusting the throttle valve on the measuring line of the regulator unit (see page 36)</i>
	Diaphragm of the regulator unit is defective	<i>Perform maintenance on regulator unit (see page 47), possibly replace regulator unit</i>
The pressure that needs to be regulated is not being regulated	The regulator unit's pilot spring is not compatible with the desired control range	Remove the pilot spring and check the color code against the control ranges listed in the spare parts list
	Pilot spring of the regulator unit is defective	Remove the pilot spring and check it for damage
The sealing pressure is too high	The control diaphragm is too hard	Check the regulator unit's control diaphragm
	The edge of the nozzle is damaged	Check the edge of the nozzle for damage.
Leaks on the outside	The screws and/or fittings were not tightened correctly	Check the tightening torques
	The gaskets are faulty	Check the gaskets for damage
Leaks on the inside	Diaphragm of the regulator unit defective	Check the regulator unit's diaphragm for damage
	Valve plate is defective	Check valve plate for damage

Malfunction	Possible causes	Correction
Unstable outlet pressure behavior (oscillations)	The regulator is not being operated with sufficient differential pressure	Increase the differential pressure with the regulator
	The regulator unit's diaphragm is too soft	Check the regulator unit's diaphragm; contact the manufacturer if necessary
	The throttle valve setting is not correct	<i>Adjusting the throttle valve on the measuring line of the regulator unit (see page 36)</i>

8 Maintenance

Contents

Topic	Page
Maintenance schedule	39
Preparing for the maintenance	40
Starting maintenance	41
Removing the regulator unit	43
Dismounting the controller	45
Performing maintenance on regulator unit	47
Installing the regulator unit	61
Maintaining the monitoring device	62
Installing the controller	62
Completing the maintenance	63

8.1 Maintenance schedule

Meaning

The maintenance schedule provides an overview of the periodically required maintenance and repairs and makes reference to the appropriate instructions.

Note: The maintenance intervals specified below are recommendations only. Since the intervals for maintenance work depend heavily on the system's operating conditions and on the gas' properties, the maintenance intervals specified below may have to be adjusted based on the relevant operating requirements and experience. Maintenance must be carried out in compliance with all federal and state laws and regulations, as well as with the local rules and regulations set forth by the relevant utilities and authorities and any other applicable regulations.

Maintenance schedule

Perform the following maintenance and repairs within the specified time intervals:

Task	See section	Interval			
		as needed	every 3 months	every year	every 5 years
Performing maintenance on regulator unit	<i>Performing maintenance on regulator unit (see page 47)</i>			●	
Maintaining the monitoring device	<i>Perform maintenance on the controller; see component documentation included in delivery</i>			●	

8.2 Preparing for the maintenance

Preparation work for maintenance

Proceed as follows:

Step	Description	Explanation
1	Have the maintenance and servicing parts ready	<p>Please refer to <i>Additional information regarding spare parts</i> (see page 67) to find out which bills of materials correspond your specific gas pressure regulator model and have the corresponding maintenance parts and servicing parts ready to go before maintenance.</p> <ul style="list-style-type: none"> ▪ The spare parts that are always required for maintenance of the regulator unit are defined in the regulator unit spare parts kits. ▪ The spare parts that are always required for the controller's maintenance are listed in the spare parts kits for the controller. ▪ Spare part drawings and bills of materials are listed in the <i>appendix</i> (see page 67). <p>In addition to these maintenance parts, there are also servicing parts that need to be checked during maintenance in order to make sure that they are in working condition. Depending on their condition, these must be replaced as needed. Because of this, it is recommended to have the following servicing parts ready for maintenance in order to avoid downtimes:</p> <p>For the controller:</p> <ul style="list-style-type: none"> ▪ Locking ring ▪ Balls <p>For the regulator unit:</p> <ul style="list-style-type: none"> ▪ Nozzle assembly
2	Preparing special tools	<p>In addition to standard tools, have the special tools required for your specific gas pressure regulator model ready to go before maintenance. Please refer to the <i>Special tools</i> section in <i>Lubricants, threadlockers, and special tools</i> (see page 78).</p> <p>You will also need a magnetic bowl for the maintenance of your controller to enable removal of the balls of the guide sleeve.</p>
3	Have the required lubricants and threadlockers ready	<p>For specifications concerning the lubricants and threadlockers that must be used, please refer to the sections of the same name under <i>Lubricants, threadlockers, and special tools</i> (see page 78).</p>

Sample maintenance instructions

The maintenance instructions below are provided as examples for the various gas pressure regulator models and versions. Use the bills of materials to make sure that you replace all the maintenance parts relevant to your specific device model during maintenance.

8.3 Starting maintenance

Pressurized parts

⚠ WARNING

Risk of serious injury posed by pressurized components moving in an uncontrolled manner when handled improperly.

If not handled properly or in the event of a defect, gas can escape from pressurized components under high pressure and cause serious injuries and even death. Before you start working on these components:

- ⇒ Close all connections leading to the gas-carrying line.
- ⇒ Establish a depressurized status. Residual amounts of energy must be depressurized as well.

Overview

Schematic diagram using the RE1 DN50 and HON 673 as a reference:

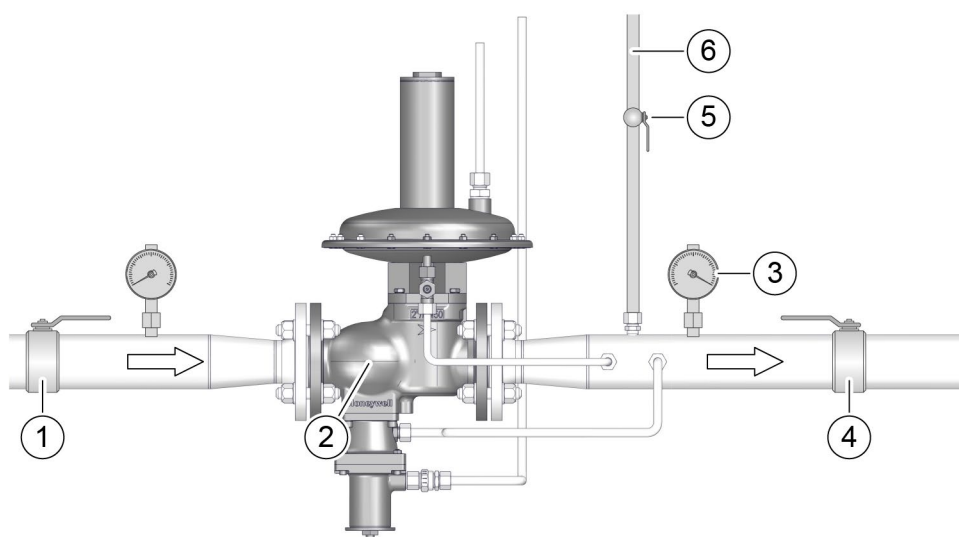

The numbers have the following meaning:

No.	Meaning
1	Inlet stop valve armature
2	Gas pressure regulator
3	Pressure gauge
4	Outlet stop valve armature
5	Valve for blowdown line
6	Blowdown line

Establishing the depressurized status

Proceed as follows:

Step	Description
1	Close the outlet stop valve armature (4).
2	Close the inlet stop valve armature (1).
3	Depressurize the gas pressure regulator.
4	Open the ball valve (5) in the blowdown line (6) to discharge the pressure between the inlet and the outlet valves.

Purging the lines with nitrogen

All the gas pressure regulator's lines must be purged with nitrogen before the device is removed.

Protecting the pipe connections from being twisted

When conducting work involving the pipework, please always observe the following:

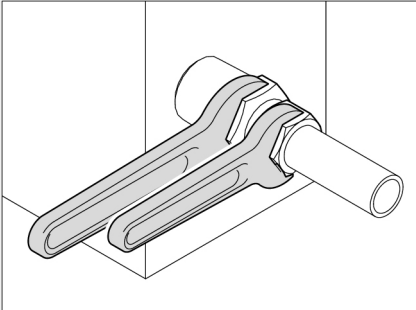
Figure	Description
	<p>Do not twist the pipe connections in the assemblies. Use a second spanner wrench for securing when loosening and tightening pipe joints.</p>

Removing components

If ...	then ...
<p>You want to perform maintenance on the regulator unit only</p>	<ul style="list-style-type: none"> ▪ The measuring line and the vent line on the regulator unit must be removed. ▪ The regulator must be removed from the gas pressure regulator body. ▪ The gas pressure regulator, including the pipes, can remain in the gas regulating line.
<p>You want to perform maintenance on the controller only</p>	<ul style="list-style-type: none"> ▪ The measuring line and the vent line on the controller must be removed. ▪ The controller must be removed from the gas pressure regulator body. ▪ The gas pressure regulator can remain in the gas regulating line.
<p>You want to perform maintenance on both the regulator unit and the controller</p>	<ul style="list-style-type: none"> ▪ The measuring line and the vent line on the regulator unit and on the controller must be removed. ▪ The regulator unit and the controller must be removed from the gas pressure regulator body. ▪ The gas pressure regulator, including the pipes, can remain in the gas regulating line.

8.4 Removing the regulator unit

Moving heavy weights

⚠ WARNING

Risk of injury due to improper lifting

When lifting and handling device components, the weight of the components and assemblies can result in injury, especially in the torso area.

- ⇒ Make sure to always have enough people lifting heavy device components (guideline using metric units: 15 - max. 55 kg / guideline using imperial units: 30 - max. 120 lbs, depending on age and gender). Comply with all the occupational health and safety regulations and instructions that apply at the installation location!
- ⇒ Use suitable hoisting equipment and slings in order to handle heavy device components. Make sure to take into account the device components' center of gravity and to attach the slings only to the secure device component locations intended for this purpose.
- ⇒ Wear the required personal protective equipment.

Falling components

⚠ CAUTION

Crush and impact hazard posed by components falling or toppling over accidentally.

When working with heavy components that have been removed or are yet to be installed, injury may result if the components start moving in an uncontrolled manner, e.g., fall down from the working surface or topple over.

- ⇒ Place removed components exclusively on level, horizontal working surfaces with enough load-bearing capacity.
- ⇒ If necessary, secure removed components so that they will not fall or topple over.
- ⇒ Wear the required personal protective equipment.
- ⇒ Exercise caution when performing the relevant tasks.

Requirements

Make sure that the following requirements are met:

- The system is not pressurized, see *Starting maintenance* (see page 41).
WARNING! Mortal danger associated with pressurized components.

Removing the regulator unit from the body

Proceed as follows:

Figure	Step	Description
	1	Disconnect the connecting lines of the regulator unit (1) and (2).

Figure	Step	Description
	2	Unscrew the screws (1) and remove the locking washers (2) to separate the regulator unit from the body.
	3	Remove the regulator unit from the body.

Next task

Depending on what you want to do next, proceed as indicated in the relevant section:

- *Performing maintenance on regulator unit (see page 47)*

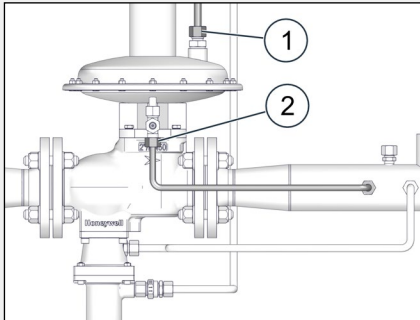
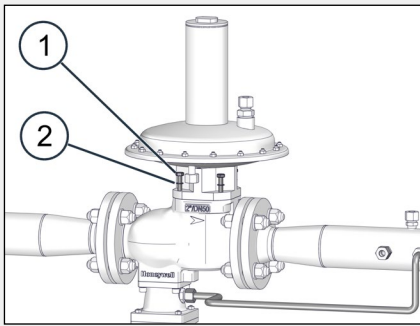
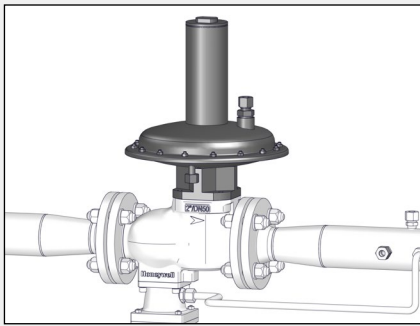
8.5 Dismounting the controller

Moving heavy weights

⚠ WARNING

Risk of injury due to improper lifting

When lifting and handling device components, the weight of the components and assemblies can result in injury, especially in the torso area.

- ⇒ Make sure to always have enough people lifting heavy device components (guideline using metric units: 15 - max. 55 kg / guideline using imperial units: 30 - max. 120 lbs, depending on age and gender). Comply with all the occupational health and safety regulations and instructions that apply at the installation location!
- ⇒ Use suitable hoisting equipment and slings in order to handle heavy device components. Make sure to take into account the device components' center of gravity and to attach the slings only to the secure device component locations intended for this purpose.
- ⇒ Wear the required personal protective equipment.

Falling components

⚠ CAUTION

Crush and impact hazard posed by components falling or toppling over accidentally.

When working with heavy components that have been removed or are yet to be installed, injury may result if the components start moving in an uncontrolled manner, e.g., fall down from the working surface or topple over.

- ⇒ Place removed components exclusively on level, horizontal working surfaces with enough load-bearing capacity.
- ⇒ If necessary, secure removed components so that they will not fall or topple over.
- ⇒ Wear the required personal protective equipment.
- ⇒ Exercise caution when performing the relevant tasks.

Requirements

Make sure that the following requirements are met:

- The system is not pressurized, see *Starting maintenance* (see page 41).
WARNING! Mortal danger associated with pressurized components.

Removing the controller from the body

Proceed as follows:

Figure	Step	Description
	1	Disconnect the connecting lines of the controller (1) and (2).

Figure	Step	Description
	2	Unscrew the screws (2) and remove the locking washers (1) to separate the controller from the body.
	3	Remove the controller from the body.

Next task

Depending on what you want to do next, proceed as indicated in the relevant section:

- *Perform maintenance on the controller; see component documentation*
- *Installing the controller (see page 62)*

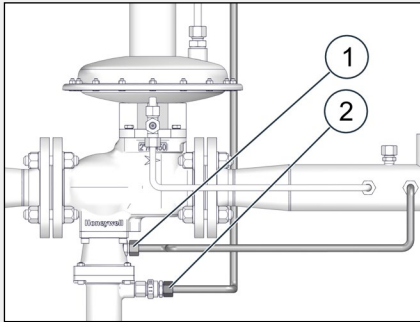
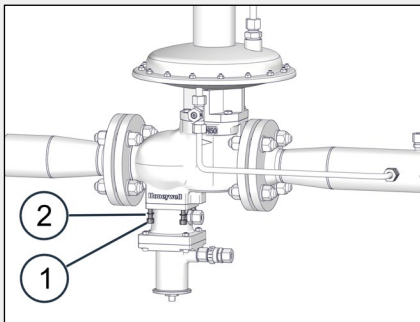
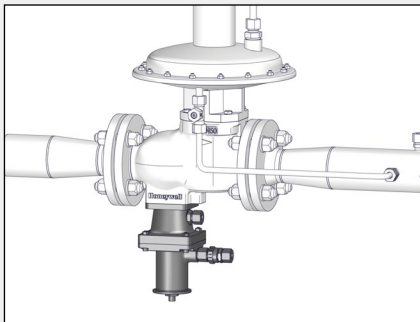
8.6 Performing maintenance on regulator unit

Contents

Topic	Page
Performing maintenance on regulator unit RE1	47
Performing maintenance on regulator unit RE2	51
Performing maintenance on regulator unit RE0	56

8.6.1 Performing maintenance on regulator unit RE1

Requirements

Make sure that the following requirements are met:

- The system is not pressurized, see *Starting maintenance* (see page 41).
WARNING! Mortal danger associated with pressurized components.

Cleaning

Observe the following cleaning instructions:

- Before assembly, all parts must be cleaned in order to remove any foreign particles (swarf) and soiling.
- If screws, bolts, or washers are replaced with identical new parts, any oil on these new parts must first be removed.

Performing maintenance on regulator unit

Proceed as follows:

Figure	Step	Description
	1	Unscrew the cap (1). Remove the gasket (2).
	2	Slowly screw out the spring adjuster (1). CAUTION! The diaphragm housing cover is spring-loaded. Risk of injury due to springing up when the spring adjuster is unscrewed.
	3	Take out the following parts: <ul style="list-style-type: none"> ▪ Spring adjuster (1) ▪ Bearing washer (2) ▪ Bearing collar (3) ▪ Bearing washer (4) ▪ Pilot spring (5)

Figure	Step	Description
	4	Unscrew and remove the screws (1) and nuts (2) of the diaphragm housing cover.
	5	Lift off the diaphragm housing cover.
	6a	<p>*) Unscrew the nut (1) and take out the following parts:</p> <ul style="list-style-type: none"> ▪ Washer (2) ▪ Centering cap (3) ▪ Spring plate (4)
*Version up to 300 mbar		
	6b	<p>**) Take out the following parts:</p> <ul style="list-style-type: none"> ▪ Spring mandrel (1) ▪ Axial needle roller bearing (2)
	6b	<p>Unscrew the nut (1) and take out the following parts:</p> <ul style="list-style-type: none"> ▪ Washer (2) ▪ Centering cap (3) ▪ Support disc (4)
**Version up to 1000 mbar		

Figure	Step Description
	<p>7 Take out the following parts:</p> <ul style="list-style-type: none"> ▪ Diaphragm plate (1) ▪ Rolling diaphragm (2) <p>Check the rolling diaphragm for damage. Replace it if necessary. Grease the inner diaphragm bead.</p>
	<p>8 Unscrew the nut (1) and take out the check piece (2):</p>
	<p>9 Unscrew the screws (1). Take note of the gaskets (2) while doing so.</p>
	<p>10 Remove the diaphragm housing pot.</p>
	<p>11 Turn the component 180°.</p>

Figure	Step	Description
	<p>12</p>	<p>Unscrew the nut (1) and take out the following parts:</p> <ul style="list-style-type: none"> ▪ Pressure piece (2) ▪ O-ring (3) ▪ Valve plate (4) ▪ Valve cone (5) ▪ O-ring (6) <p>Replace the O-rings with new, greased O-rings.</p>
	<p>13</p>	<p>Release the circlip (1) on the marked recess.</p>
	<p>14</p>	<p>Remove the circlip (1).</p>
	<p>15</p>	<p>Take out the following parts:</p> <ul style="list-style-type: none"> ▪ Nozzle assembly (1) ▪ O-rings (2) <p>Replace the two O-rings (2) with new, greased O-rings.</p>
	<p>16</p>	<p>Turn the nozzle assembly (1) and release the locking ring (2) to remove the plain bearing (3). Check the plain bearing for damage. Replace it if necessary.</p>

Figure	Step	Description
	17	Take the valve spindle including attached parts out of the intermediate piece.
	18	<p>Unscrew the nut (1) and take out the following parts:</p> <ul style="list-style-type: none"> ▪ Pressure disc (2) ▪ Compensating diaphragm (3) <p>Check the compensating diaphragm for damage. Replace it if necessary.</p>
	19	<p>IMPORTANT! Pull out the quad ring (1) upwards so as to avoid damaging the sliding surface of the intermediate piece.</p> <p>Replace the quad ring (1) with a new, greased quad ring.</p>
	20	<p>Turn the intermediate piece and release the locking ring (1) to remove the plain bearing (2).</p> <p>Check the plain bearing for damage. Replace it if necessary.</p> <p>Replace the O-ring (3) with a new, lubricated O-ring.</p>

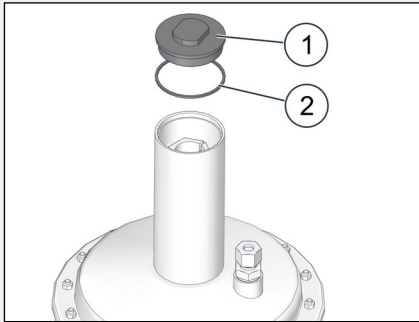
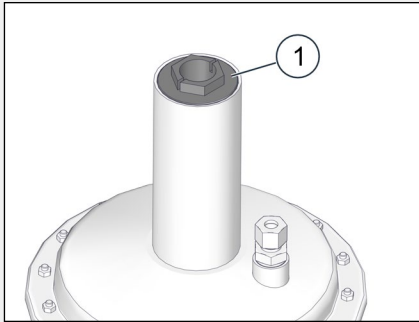
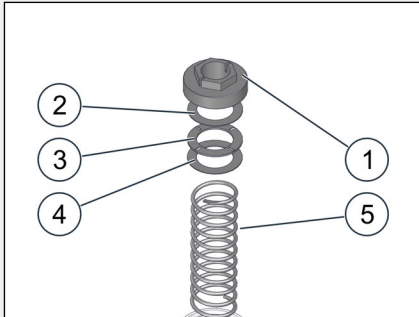
Assembling the regulator unit

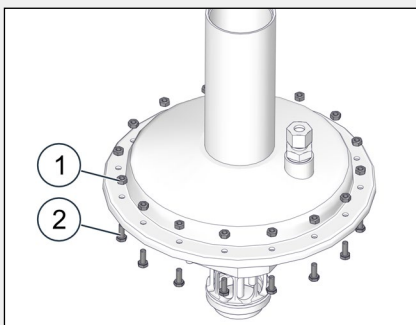
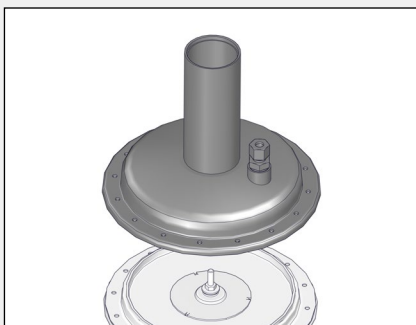
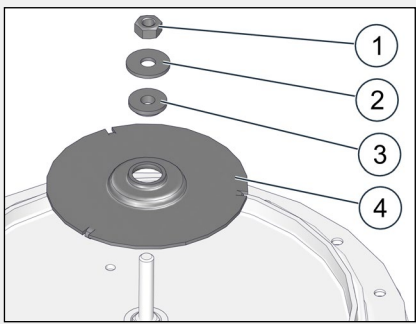
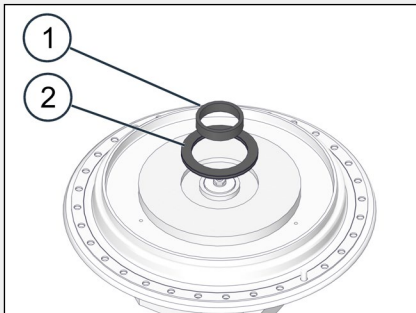
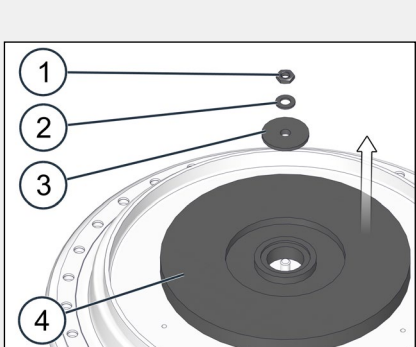
Proceed in the reverse order as for the disassembly in "Performing maintenance on the regulator unit". See above.

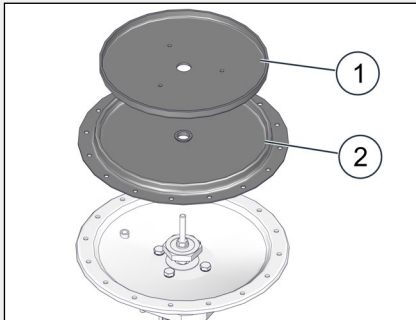
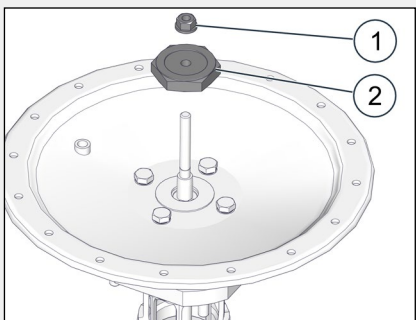
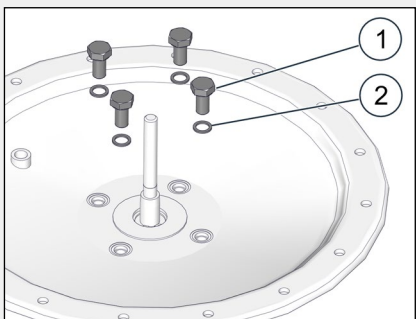
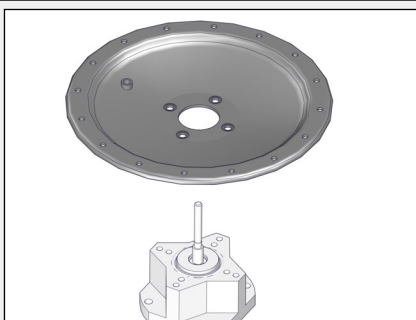
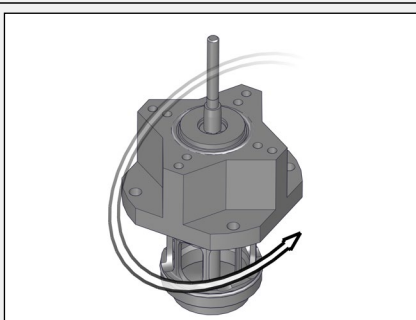
Next task

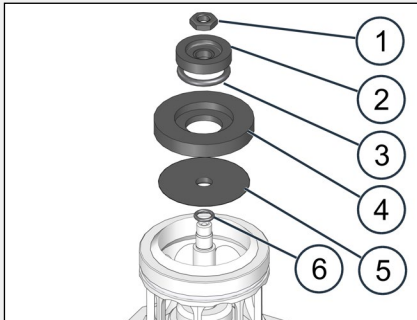
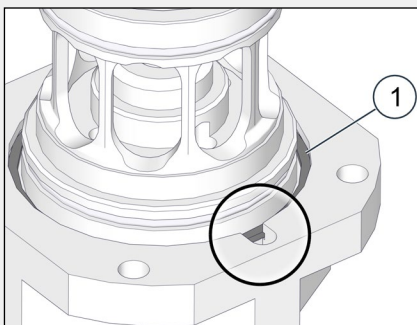
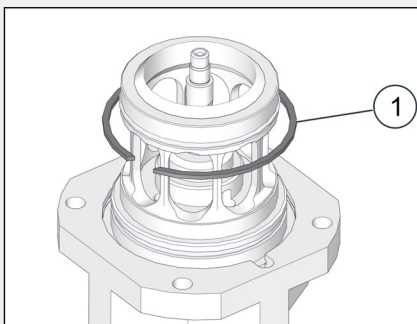
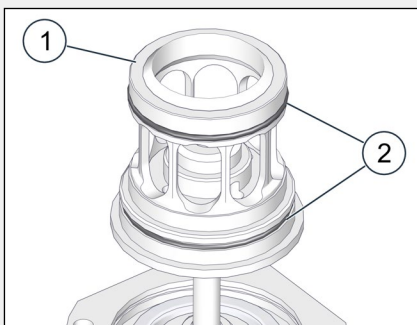
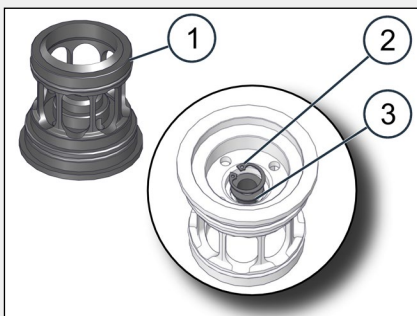
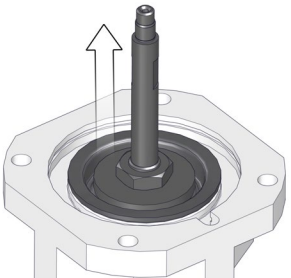
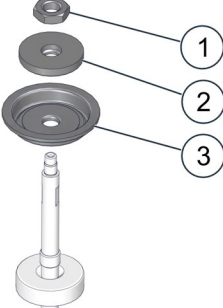
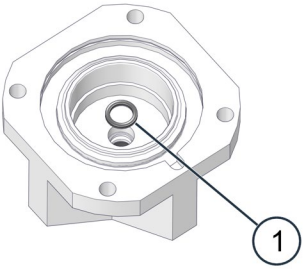
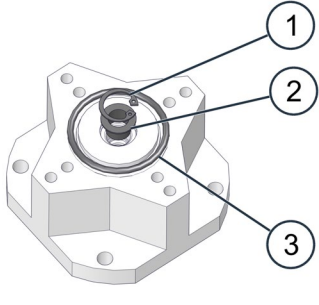
Depending on what you want to do next, proceed as indicated in the relevant section:

- *Installing the regulator unit* (see page 61)
- *Completing the maintenance* (see page 63)

8.6.2 Performing maintenance on regulator unit RE2

Requirements

Make sure that the following requirements are met:

- The system is not pressurized, see *Starting maintenance* (see page 41).
WARNING! Mortal danger associated with pressurized components.

Cleaning

Observe the following cleaning instructions:

- Before assembly, all parts must be cleaned in order to remove any foreign particles (swarf) and soiling.
- If screws, bolts, or washers are replaced with identical new parts, any oil on these new parts must first be removed.

Performing maintenance on regulator unit

Proceed as follows:

Figure	Step	Description
	1	Turn the spring adjuster to reduce the spring tension.
	2	Unscrew the flat-head screws (1). Press down the locking plate (2) to remove the half rings (3). CAUTION! The locking plate is spring-loaded. Risk of injury due to springing up when the half rings are released.
	3	Take out the following parts: <ul style="list-style-type: none"> ▪ Spring adjuster (1) ▪ Locking plate (2) ▪ Washers (3,5) ▪ Axial bearing (4) ▪ O-ring (6) ▪ Spring plate (7) ▪ Pilot spring (8) Replace the O-ring (6) with a new, lubricated O-ring.
	4	Unscrew and remove the screws (1) and nuts (2) of the diaphragm housing cover.

Figure	Step	Description
	5	Remove the diaphragm housing cover (1).
	6a	<p>*) Unscrew the nut (1) and take out the following parts:</p> <ul style="list-style-type: none"> ▪ Washer (2) ▪ Centering cap (3) ▪ Spring plate (4)
*Version up to 300 mbar		
	6b	<p>***) Take out the following parts:</p> <ul style="list-style-type: none"> ▪ Spring mandrel (1) ▪ Axial needle roller bearing (2)
	6b	<p>Unscrew the nut (1) and take out the following parts:</p> <ul style="list-style-type: none"> ▪ Washer (2) ▪ Centering cap (3) ▪ Support disc (4)
**Version up to 1000 mbar		
	7	<p>Take out the following parts:</p> <ul style="list-style-type: none"> ▪ Diaphragm plate (1) ▪ Rolling diaphragm (2) <p>Check the rolling diaphragm for damage. Replace it if necessary. Grease the inner diaphragm bead.</p>

Figure	Step	Description
	8	Unscrew the nut (1) and take out the check piece (2):
	9	Unscrew the screws (1) and remove the diaphragm housing pot (3). Take note of the gaskets (2) while doing so.
	10	Turn the component 180°.
	11	Unscrew the nut (1) and take out the following parts: <ul style="list-style-type: none"> ▪ Pressure piece (2) ▪ O-ring (3) ▪ Valve plate (4) ▪ Valve cone (5) ▪ O-ring (6) Replace the O-rings with new, greased O-rings.
	12	Release the circlip (1) on the marked recess.

Figure	Step	Description
	<p>13</p>	<p>Remove the circlip (1).</p>
	<p>14</p>	<p>Take out the following parts:</p> <ul style="list-style-type: none"> ▪ Nozzle assembly (1) ▪ O-rings (2) <p>Replace the two O-rings (2) with new, greased O-rings.</p>
	<p>15</p>	<p>Turn the nozzle assembly (1) and release the locking ring (2) to remove the plain bearing (3). Check the plain bearing for damage. Replace it if necessary.</p>
	<p>16</p>	<p>Take the valve spindle including attached parts out of the intermediate piece.</p>
	<p>17</p>	<p>Unscrew the nut (1) and take out the following parts:</p> <ul style="list-style-type: none"> ▪ Pressure disc (2) ▪ Compensating diaphragm (3) <p>Check the compensating diaphragm for damage. Replace it if necessary.</p>

Figure	Step	Description
	18	<p>IMPORTANT! Pull out the quad ring (1) upwards so as to avoid damaging the sliding surface of the intermediate piece.</p> <p>Replace the quad ring (1) with a new, greased quad ring.</p>
	19	<p>Turn the intermediate piece and release the locking ring (1) to remove the plain bearing (2).</p> <p>Check the plain bearing for damage. Replace it if necessary.</p> <p>Replace the O-ring (3) with a new, lubricated O-ring.</p>

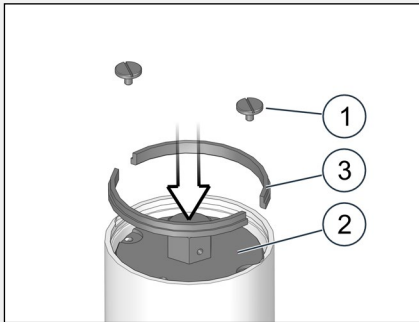
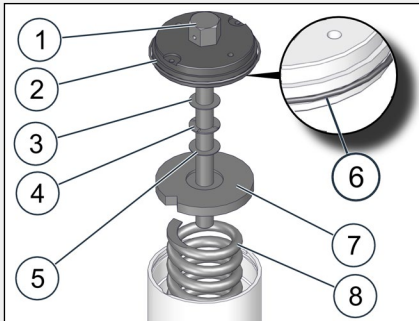
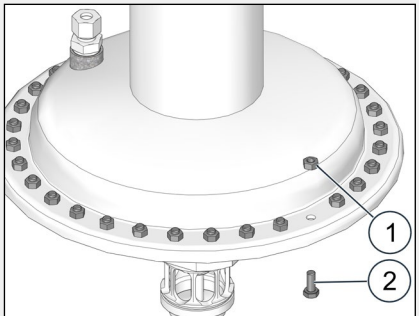
Assembling the regulator unit

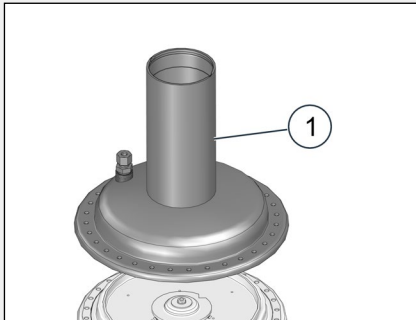
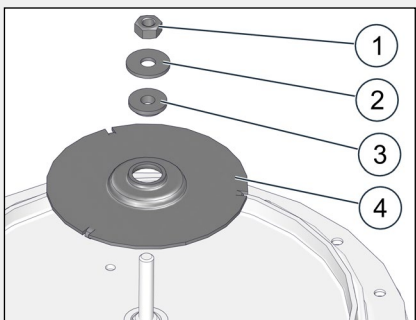
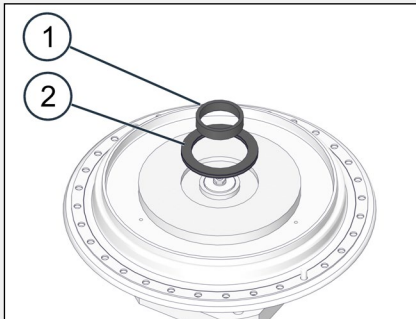
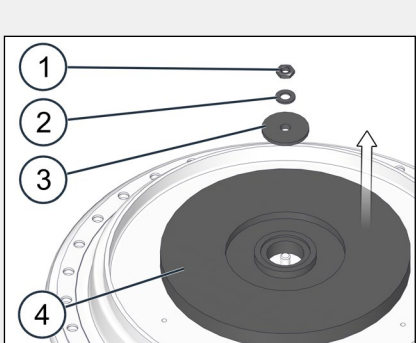
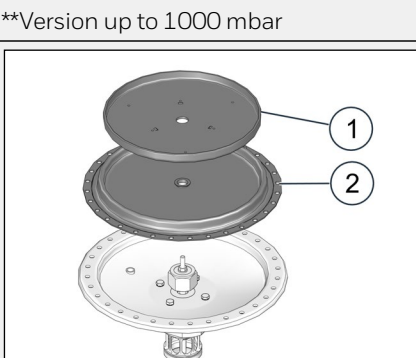
Proceed in the reverse order as for the disassembly in "Performing maintenance on the regulator unit". See above.

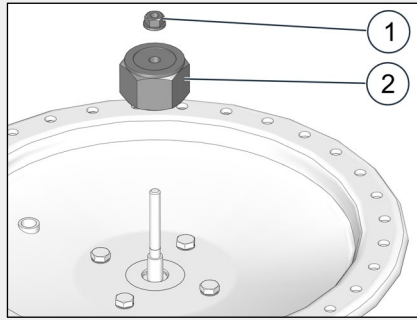
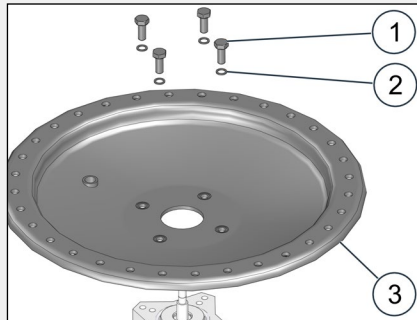
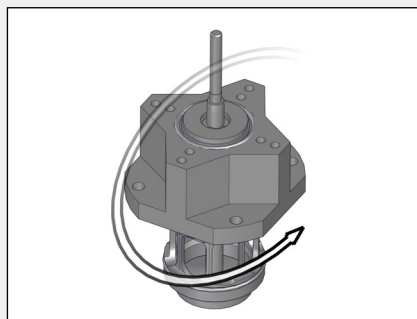
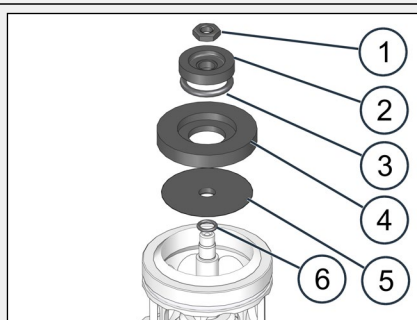
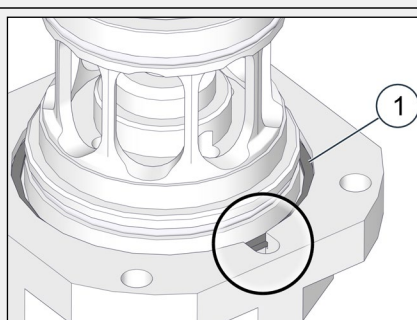
Next task

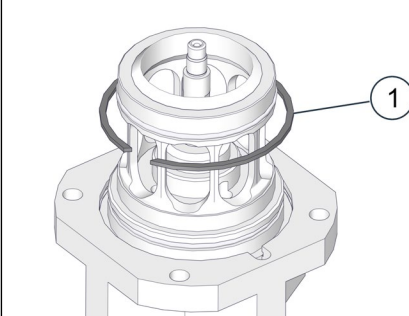
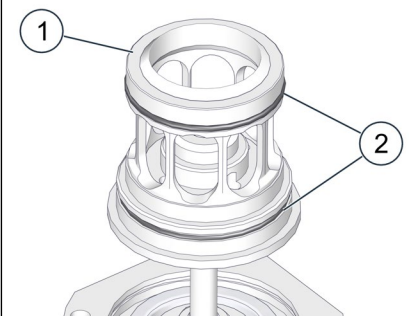
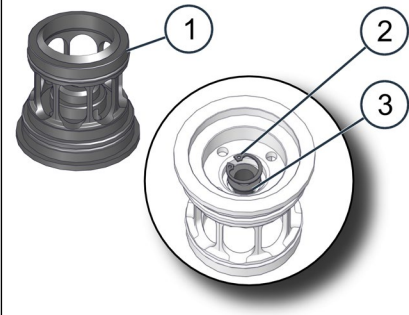
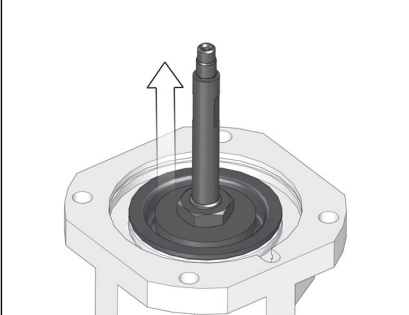
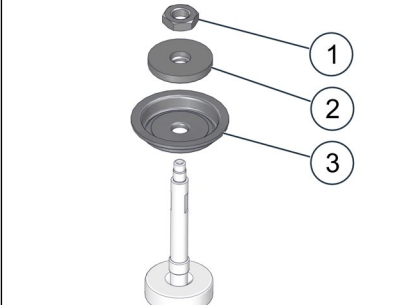
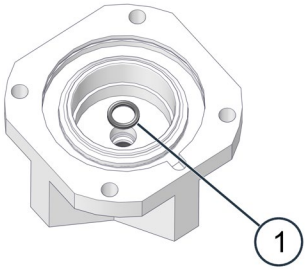
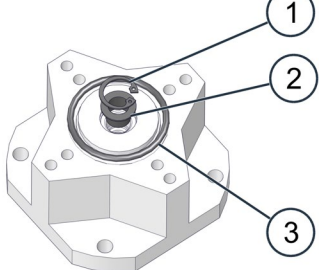
Depending on what you want to do next, proceed as indicated in the relevant section:

- *Installing the regulator unit* (see page 61)
- *Completing the maintenance* (see page 63)

8.6.3 Performing maintenance on regulator unit REO

Requirements

Make sure that the following requirements are met:

- The system is not pressurized, see *Starting maintenance* (see page 41).
WARNING! Mortal danger associated with pressurized components.

Cleaning

Observe the following cleaning instructions:

- Before assembly, all parts must be cleaned in order to remove any foreign particles (swarf) and soiling.
- If screws, bolts, or washers are replaced with identical new parts, any oil on these new parts must first be removed.

Performing maintenance on regulator unit

Proceed as follows:

Figure	Step	Description
	1	Turn the spring adjuster to reduce the spring tension.
	2	Unscrew the flat-head screws (1). Press down the locking plate (2) to remove the half rings (3). CAUTION! The locking plate is spring-loaded. Risk of injury due to springing up when the half rings are released.
	3	Take out the following parts: <ul style="list-style-type: none"> ▪ Spring adjuster (1) ▪ Locking plate (2) ▪ Washers (3,5) ▪ Axial bearing (4) ▪ Spring plate (7) ▪ Pilot spring (8) Replace the O-ring (6) with a new, lubricated O-ring.
	4	Unscrew and remove the screws (1) and nuts (2) of the diaphragm housing cover. Take note of the washers (2) while doing so.

Figure	Step Description
	<p>5 Remove the diaphragm housing cover (1).</p>
	<p>6 Take out the following parts:</p> <ul style="list-style-type: none"> ▪ Axial needle roller bearing (1) ▪ Spring mandrel (2) <p>Unscrew the nut (3) and take out the following parts:</p> <ul style="list-style-type: none"> ▪ Washer (4) ▪ Diaphragm plate (5) ▪ Diaphragm (6) ▪ Check piece (7)
	<p>7 Replace the O-ring (1) with a new, lubricated O-ring.</p>
	<p>8 Unscrew the screws (1) and remove the diaphragm housing pot (3). Take note of the gaskets (2) while doing so.</p>
	<p>9 Turn the component 180°.</p>

Figure	Step	Description
	<p>10</p>	<p>Unscrew the nut (1) and take out the following parts:</p> <ul style="list-style-type: none"> ▪ Pressure piece (2) ▪ O-ring (3) ▪ Valve plate (4) ▪ Valve cone (5) ▪ O-ring (6) <p>Replace the O-rings with new, greased O-rings.</p>
	<p>11</p>	<p>Release the circlip (1) on the marked recess.</p>
	<p>12</p>	<p>Remove the circlip (1).</p>
	<p>13</p>	<p>Take out the following parts:</p> <ul style="list-style-type: none"> ▪ Nozzle assembly (1) ▪ O-rings (2) <p>Replace the two O-rings (2) with new, greased O-rings.</p>
	<p>14</p>	<p>Turn the nozzle assembly (1) and release the locking ring (2) to remove the plain bearing (3). Check the plain bearing for damage. Replace it if necessary.</p>

Figure	Step	Description
	15	Take the valve spindle including attached parts out of the intermediate piece.
	16	<p>Unscrew the nut (1) and take out the following parts:</p> <ul style="list-style-type: none"> ▪ Pressure disc (2) ▪ Compensating diaphragm (3) <p>Check the compensating diaphragm for damage. Replace it if necessary.</p>
	17	<p>IMPORTANT! Pull out the quad ring (1) upwards so as to avoid damaging the sliding surface of the intermediate piece.</p> <p>Replace the quad ring (1) with a new, greased quad ring.</p>
	18	<p>Turn the intermediate piece and release the locking ring (1) to remove the plain bearing (2).</p> <p>Check the plain bearing for damage. Replace it if necessary.</p> <p>Replace the O-ring (3) with a new, lubricated O-ring.</p>

Assembling the regulator unit

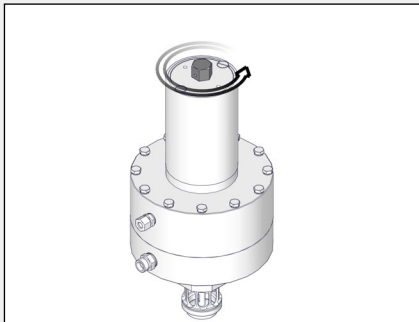
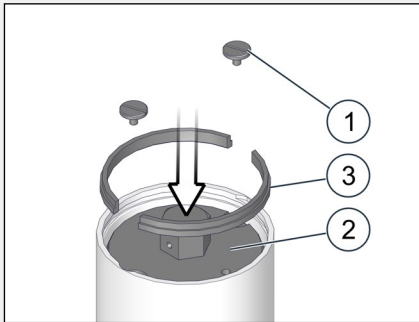
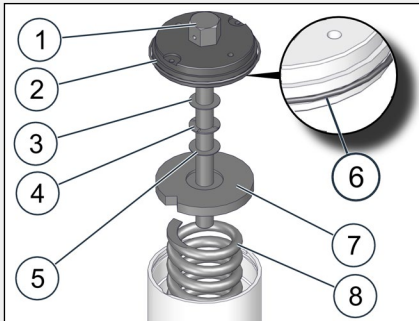
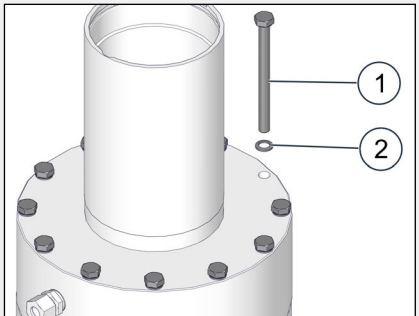
Proceed in the reverse order as for the disassembly in "Performing maintenance on the regulator unit". See above.

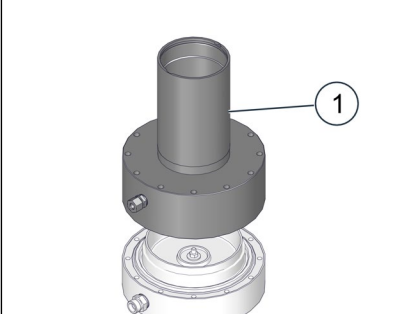
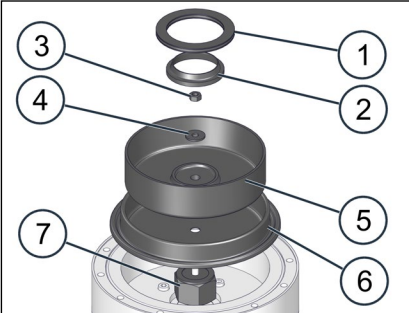
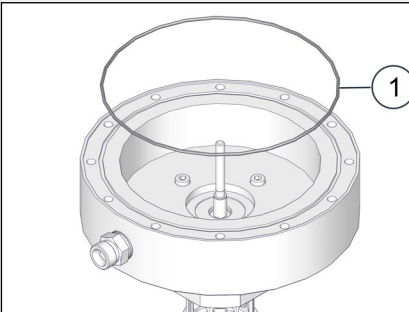
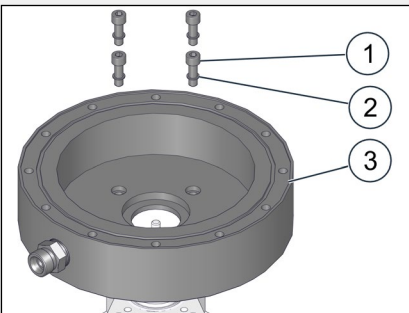
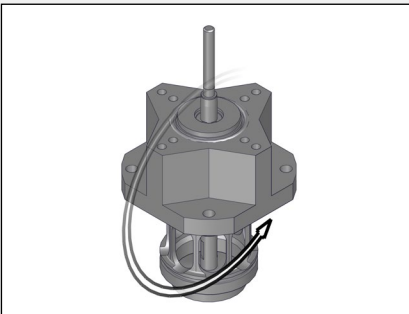
Next task

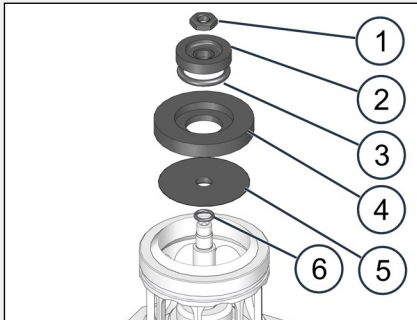
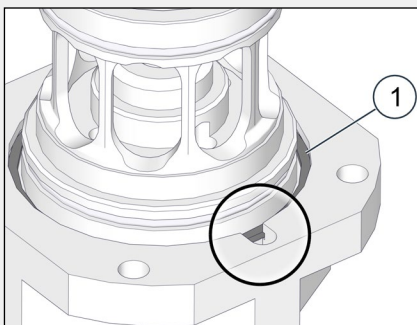
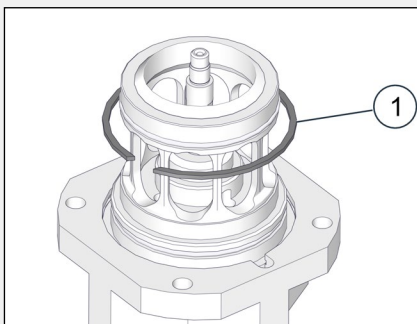
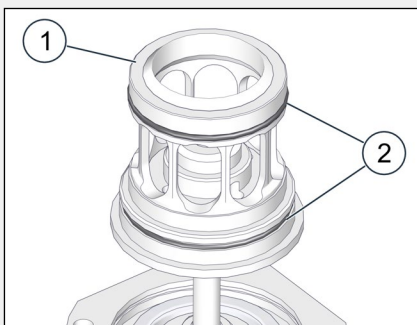
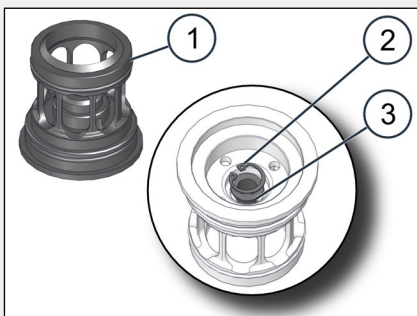
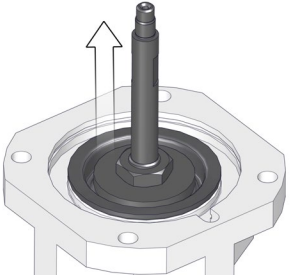
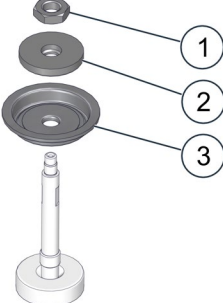
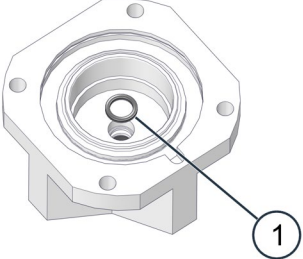
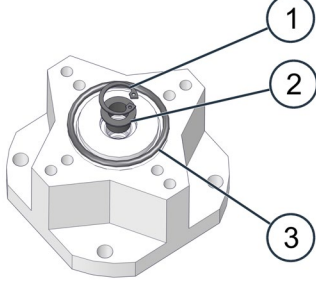
Depending on what you want to do next, proceed as indicated in the relevant section:

- *Installing the regulator unit* (see page 61)
- *Completing the maintenance* (see page 63)

8.7 Installing the regulator unit

Falling components

⚠ CAUTION

Crush and impact hazard posed by components falling or toppling over accidentally.

When working with heavy components that have been removed or are yet to be installed, injury may result if the components start moving in an uncontrolled manner, e.g., fall down from the working surface or topple over.

- ⇒ Place removed components exclusively on level, horizontal working surfaces with enough load-bearing capacity.
- ⇒ If necessary, secure removed components so that they will not fall or topple over.
- ⇒ Wear the required personal protective equipment.
- ⇒ Exercise caution when performing the relevant tasks.

Cleaning

Observe the following cleaning instructions:

- Before assembly, all parts must be cleaned in order to remove any foreign particles (swarf) and soiling.
- If screws, bolts, or washers are replaced with identical new parts, any oil on these new parts must first be removed.

Installing the regulator unit on the body

Proceed as follows:

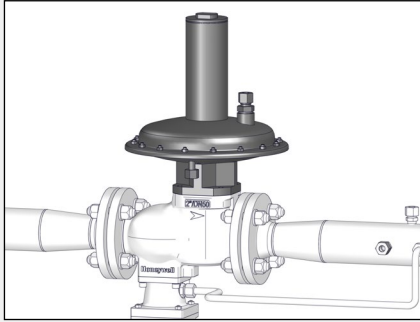
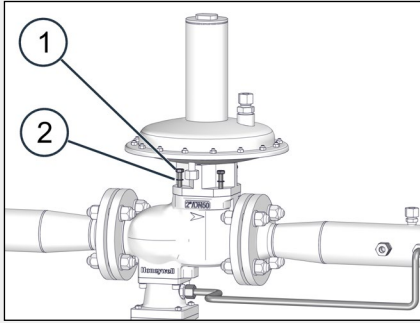
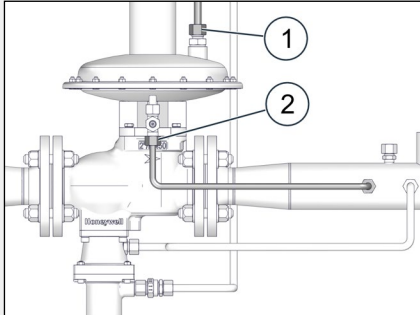
Figure	Step	Description
	1	Insert the regulator unit into the body.
	2	Tighten the screws (1) with the locking washers (2) in a criss-cross sequence. Tightening torque: 20 Nm
	3	Reinstall all the pipes you removed previously on the regulator unit. <ul style="list-style-type: none"> ▪ Vent line (1) ▪ Measuring line (2)

8.8 Maintaining the monitoring device

Cleaning

Observe the following cleaning instructions:

- Before assembly, all parts must be cleaned in order to remove any foreign particles (swarf) and soiling.
- If screws, bolts, or washers are replaced with identical new parts, any oil on these new parts must first be removed.

Maintaining the monitoring device

The maintenance of the controller is described in the HON 673 / HON 674 component documentation.

Next task

Proceed as follows:

- *Installing the controller* (see page 62)
- *Completing the maintenance* (see page 63)

8.9 Installing the controller

Falling components



Crush and impact hazard posed by components falling or toppling over accidentally.

When working with heavy components that have been removed or are yet to be installed, injury may result if the components start moving in an uncontrolled manner, e.g., fall down from the working surface or topple over.

- ⇒ Place removed components exclusively on level, horizontal working surfaces with enough load-bearing capacity.
- ⇒ If necessary, secure removed components so that they will not fall or topple over.
- ⇒ Wear the required personal protective equipment.
- ⇒ Exercise caution when performing the relevant tasks.

Cleaning

Observe the following cleaning instructions:

- Before assembly, all parts must be cleaned in order to remove any foreign particles (swarf) and soiling.
- If screws, bolts, or washers are replaced with identical new parts, any oil on these new parts must first be removed.

Installing the controller in the body

Proceed as follows:

Figure	Step	Description
	1	Insert the controller into the body.

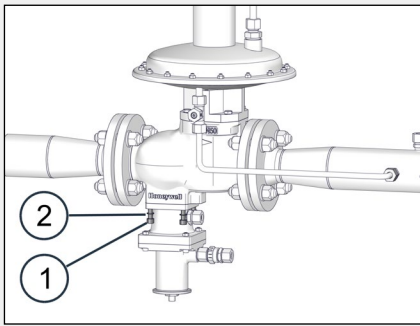
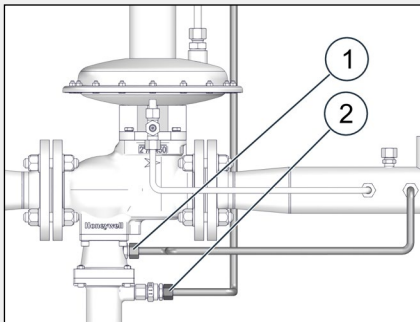
Figure	Step	Description
	2	Tighten the screws (1) with the locking washers (2) in a criss-cross sequence. Tightening torque: 20 Nm
	3	Reinstall all the pipes you removed previously on the monitoring device. <ul style="list-style-type: none"> ▪ Measuring line (1) ▪ Vent line (2)

Next task

Depending on what you want to do next, proceed as indicated in the relevant section:

- *Completing the maintenance* (see page 63)

8.10 Completing the maintenance

Protecting the pipe connections from being twisted

When conducting work involving the pipework, please always observe the following:

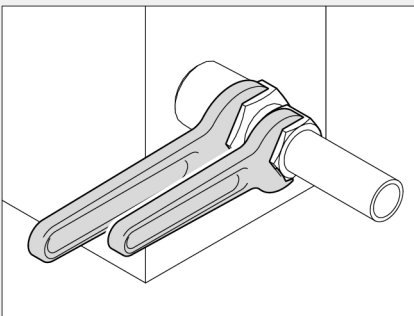
Figure	Description
	<p>Do not twist the pipe connections in the assemblies.</p> <p>Use a second spanner wrench for securing when loosening and tightening pipe joints.</p>

Next task

Proceed as follows:

Checking the system for leaks (see page 31)

9 Storage, removal, and disposal

Contents

Topic	Page
Storing the device	64
Disassembling the device	65
Disposing of the device	66

9.1 Storing the device

Storage of the packing units

Observe the following rules:

- Do not store the device outdoors.
- Store the device in a dry and dust-free environment on a flat surface.
- Do not expose the device to any aggressive media, ozone or ionizing radiation or to direct heat sources.
- Storage conditions:
 - Temperature: 0 °C to 25 °C (32 °F to 77 °F)
 - Relative humidity: < 55 %.
- Avoid mechanical vibrations.
- Storage periods:
 - When storing the device for up to one year:
Store the device in its original packaging and in the same condition it was delivered. All protective caps of the device must remain in place.
 - When storing the device for more than one year (e.g., as a backup device):
Store the device in its original packaging and in the same condition it was delivered and check it annually for damage and soiling.
Consider the storage period in the maintenance cycles.

Note: Please also observe any storage information provided on the packaging.

Storage of spare parts

The following rules apply to the storage of spare parts:

- Apply an appropriate protective agent to assemblies at risk of corrosion.
 - If stored correctly, O-rings and gaskets should not be kept longer than 7 years.
 - Store the spare parts in the original package until they are used.
-

9.2 Disassembling the device

Pressurized parts

⚠ WARNING

Risk of serious injury posed by pressurized components moving in an uncontrolled manner when handled improperly.

If not handled properly or in the event of a defect, gas can escape from pressurized components under high pressure and cause serious injuries and even death. Before you start working on these components:

- ⇒ Close all connections leading to the gas-carrying line.
- ⇒ Establish a depressurized status. Residual amounts of energy must be depressurized as well.

Overview

Schematic diagram using the RE1 DN50 and HON 673 as a reference:

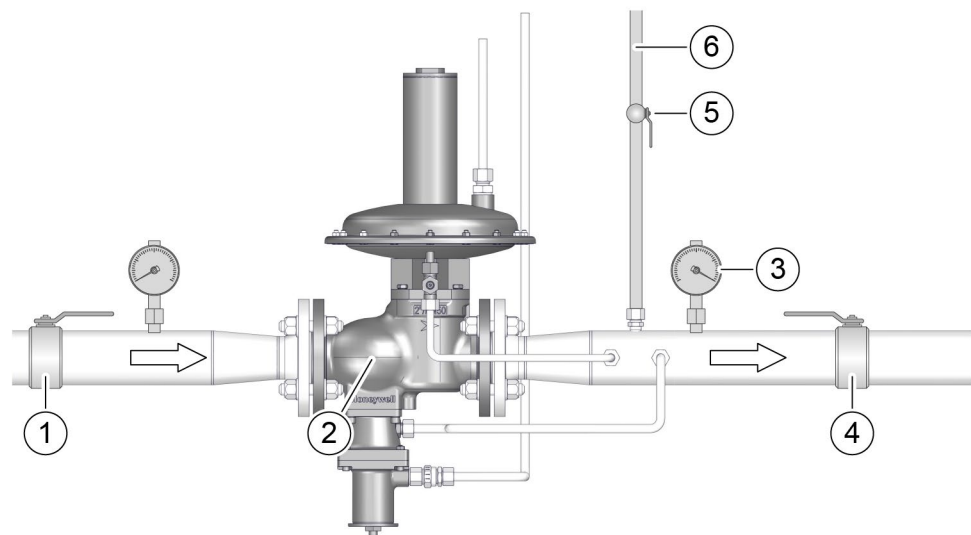

The numbers have the following meaning:

No.	Meaning
1	Inlet stop valve armature
2	Gas pressure regulator
3	Pressure gauge
4	Outlet stop valve armature
5	Valve for blowdown line
6	Blowdown line

Establishing the depressurized status

Proceed as follows:

Step	Description
1	Close the outlet stop valve armature (4).
2	Close the inlet stop valve armature (1).
3	Depressurize the gas pressure regulator.
4	Open the ball valve (5) in the blowdown line (6) to discharge the pressure between the inlet and the outlet valves.

Protecting the pipe connections from being twisted

When conducting work involving the pipework, please always observe the following:

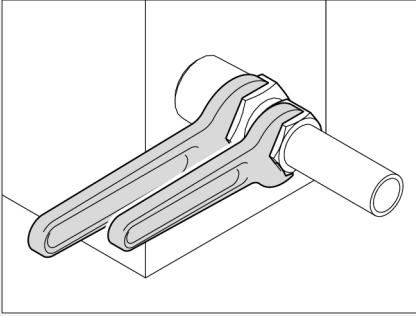
Figure	Description
	<p>Do not twist the pipe connections in the assemblies.</p> <p>Use a second spanner wrench for securing when loosening and tightening pipe joints.</p>

Purging the lines with nitrogen

All the gas pressure regulator's lines must be purged with nitrogen before the device is removed.

Disassembling the device

Proceed as follows:

Step	Description
1	Disassemble the device. Observe the information and instructions in the <i>Transport and installation</i> (see page 27) section when doing so.

9.3 Disposing of the device

Appropriate disposal

Comply with the legally stipulated disposal rules. Observe the following details pertaining to the appropriate disposal (not all of the items may be applicable to your device):

- Dispose of the metals according to their types and grades (steel scrap, cast iron scrap, light alloy scrap, nonferrous heavy metal scrap, synthetic rubber scrap, electronic scrap).
- Recycle elements made of synthetic materials.
- Dispose of any other components according to the quality of the materials.

10 Appendix

Contents

Topic	Page
Additional information regarding spare parts	67
Spare parts kit for HON 380 with RE1	69
Spare parts kit for HON 380 with RE2	71
Spare parts kit for HON 380 with RE0	75
Lubricants	78

10.1 Additional information regarding spare parts

Spare parts categories Spare parts fall into the following categories:

Spare parts category	Definition
Maintenance part	Spare parts that always have to be replaced during maintenance.
Servicing parts	Spare parts that need to be checked during maintenance and that must be replaced if necessary due to their condition.
	Spare parts that qualified personnel employed by the company operating the device is allowed to replace in order to convert the device (e.g., when changing the pressure range).
	Spare parts that qualified personnel employed by the company operating the device is allowed to replace in the event of a fault or defect.
Miscellaneous spare part	Parts that are listed in the spare part drawings in addition to maintenance and servicing parts so as to improve communications between the customer and the manufacturer, but that are not allowed to be ordered or replaced without first contacting the manufacturer.

Maintenance and servicing parts for the regulator unit

- The spare parts always required for maintenance of the regulator unit are grouped together into spare parts kits appropriate for the version in question. Each spare parts kit has its own part number.
- Individual servicing parts can be ordered using the corresponding part number, which is specified in the respective bill of materials for the regulator unit. The required number of parts is specified in the “Quantity” column.

Overview of bills of materials

The bills of materials are subdivided as follows:

- Spare parts kit for HON 380 with RE1
 - Spare part drawing
 - Maintenance and servicing parts
 - Various spare parts kits, grouped by nominal size and pressure rating
 - Spare parts kit for HON 380 with RE2
 - Spare part drawing
 - Maintenance and servicing parts
 - Various spare parts kits, grouped by nominal size and pressure rating
 - Spare parts kit for HON 380 with RE0
 - Spare part drawing
 - Maintenance and servicing parts
 - Various spare parts kits, grouped by nominal size and pressure rating
-

10.2 Spare parts kit for HON 380 with RE1

Spare parts drawing for HON 380 with RE1

Version up to 300 mbar

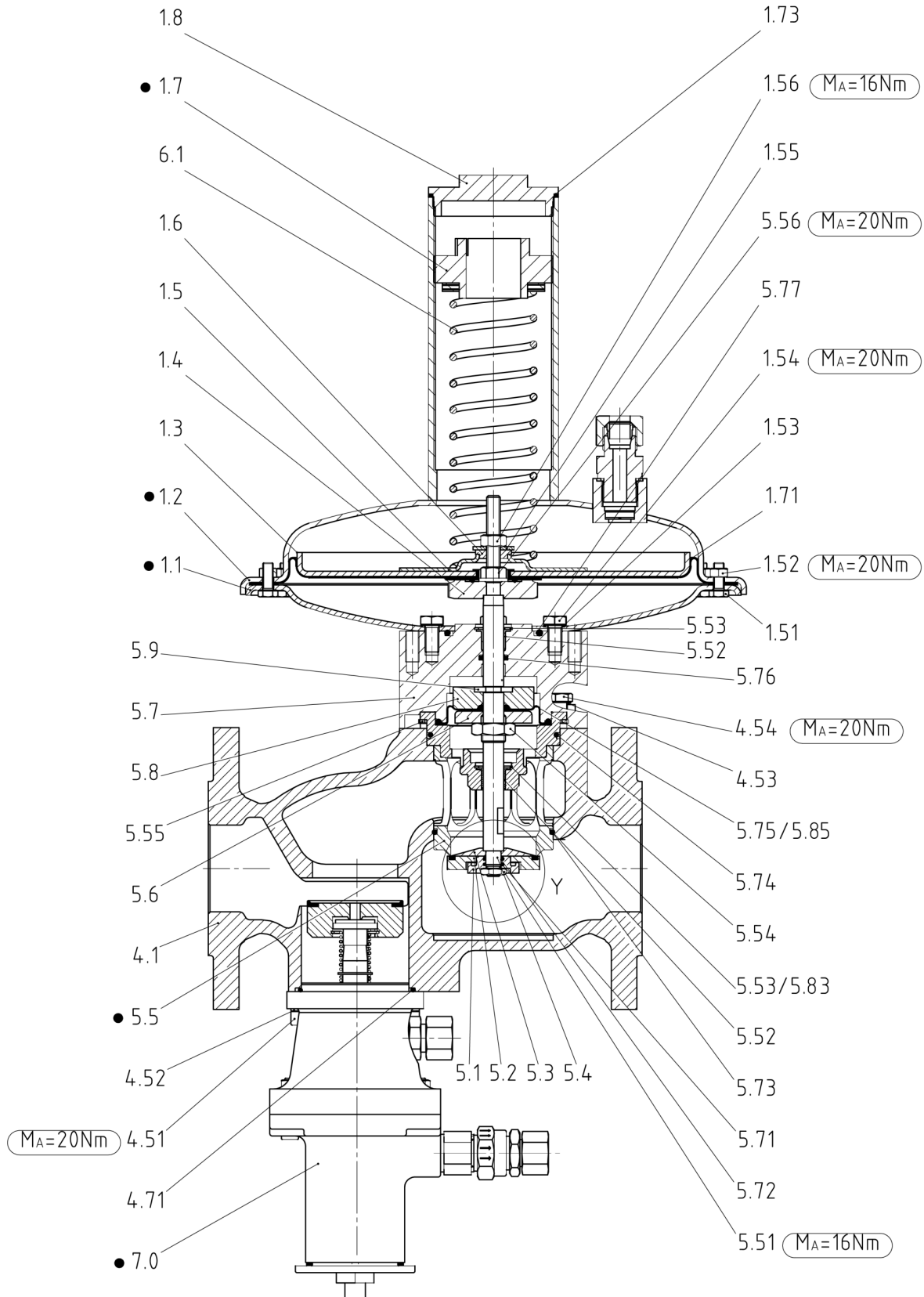

Version for 300 - 1000 mbar

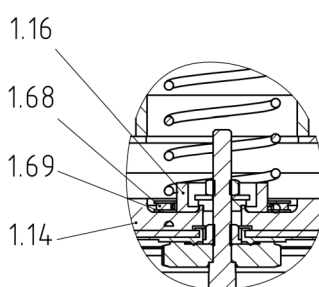

Spare parts kits for HON 380 with RE1 DN 25 - DN 50

Series 380 spare parts kits - PN16/CL150

No.	Name	Qty.	Part no.		
			DN 25	DN 50 (20 - 50 mbar)	DN 50 (50 - 1000 mbar)
Spare parts kit no.			K380-001	K380-005	K380-017
4.71	O-ring 2-144 W2.62 D 63.17	1		20513-RMK	
1.71	Diaphragm	1		10003606	
1.73	Closure gasket	1		10003640	
1.74	Rubber slotted disc	1		10003607	
5.71	O-ring 2-117 W2.62 D20.29	1		20383	
5.72	O-ring 5-6112 W1.78 D8.74	1		20341	
5.73	O-ring 2-144 W2.62 D 63.17	1	-		20513-RMK
5.83	O-ring W 3.00 D 36.20	1	20434-RMK	-	-
5.74	O-ring 2-149 W2.62 D71.12	1		20308-RMK	
5.75	Compensating diaphragm, valve seat 50	1	-		15026002
5.85	Compensating diaphragm, valve seat 25	1	15025011	-	-
5.76	Quad ring 12.37x2.62	1		103844-RMK	
5.56	Grommet nut, M8	1		13136	
5.77	O-ring 2-157 W3.53 D50.39	1		20325	
5.2	Valve plate DN 50 (pd= 20 - 50 mbar)	1	-	10032757	-
5.2	Valve plate DN 50 chamfer (pd= 50 - 1000 mbar)	1	-	-	10032929
5.2	Valve plate DN 25	1	10032756	-	-
5.52	Plain bearing G1FM-1214-12	2		103843-RMK	
5.53	Locking ring DIN472 - 21 x 1	2		103845-RMK	
1.53	Gasket A8 X 11.5	4		18710-RMK	

Optional maintenance parts

			Part no.	
Optional maintenance parts	Qty.	DN 25	DN 50	
5.5	Nozzle assembly	1	10032762	10032747-RMK
13.1	Noise abatement	1	10032774	10032775

10.3 Spare parts kit for HON 380 with RE2

Spare parts drawing for HON 380 with RE2

Version up to 300 mbar

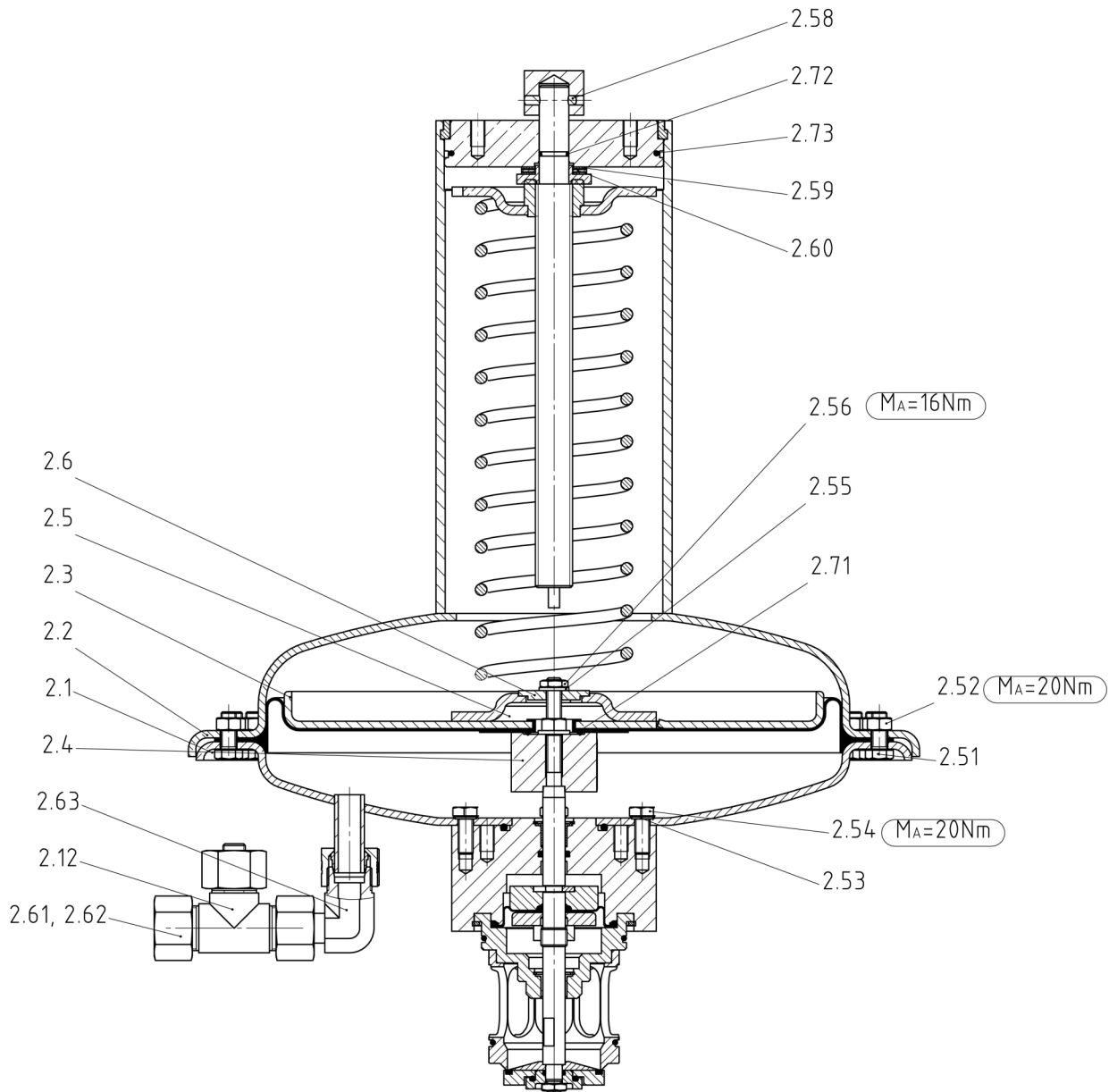

Version for 300 to 1000 mbar

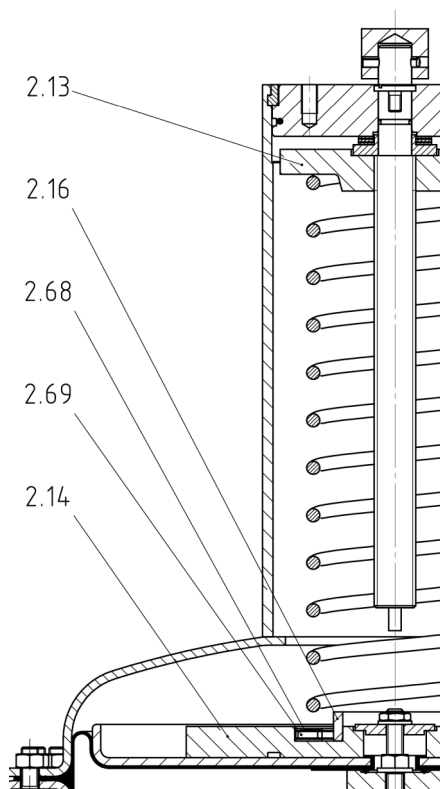

NOTE: Item nos. not shown here are shown in the version of the regulating unit *RE1*.

Spare parts kits for HON 380 with RE2 DN 50

Series 380 spare parts kits - PN16/CL150

No.	Name	Qty.	Part no.	
			NBR version (standard)	
			DN 50 (20 - 50 mbar)	DN 50 (50 - 1000 mbar)
	Spare parts kit no.		K380-006	K380-018
4.71	O-ring 2-144 W2.62 D 63.17	1		20513-RMK
2.71	Rolling diaphragm 365*1.1	1		10009046
2.73	O-ring 2-156 W2.62 D107.62	1		20248
5.71	O-ring 2-117 W2.62 D20.29	1		20383
5.72	O-ring 5-6112 W1.78 D8.74	1		20341
5.73	O-ring 2-146 W2.62 D63.17	1		20513-RMK
5.74	O-ring 2-149 W2.62 D71.12	1		20308-RMK
5.75	Compensating diaphragm, valve seat 50	1		15026002
5.76	Quad ring 12.37x2.62	1		103844-RMK
5.56	Grommet nut, M8	1		13136
5.77	O-ring 2-157 W3.53 D50.39	1		20325
5.2	Valve plate DN50 (pd= 20 - 50 mbar)	1	10032757	
5.2	Valve plate DN50 chamfer (pd= 50 - 1000 mbar)	1		10032929

			Part no. NBR version (standard)
5.52	Plain bearing G1FM-1214-12	2	103843-RMK
5.53	Locking ring DIN472 - 21 x 1	2	103845-RMK
2.53	Gasket A8 X 11.5	4	18710-RMK

DN 80 - DN 100

Version up to 300 mbar

Version for 300 to 1000 mbar

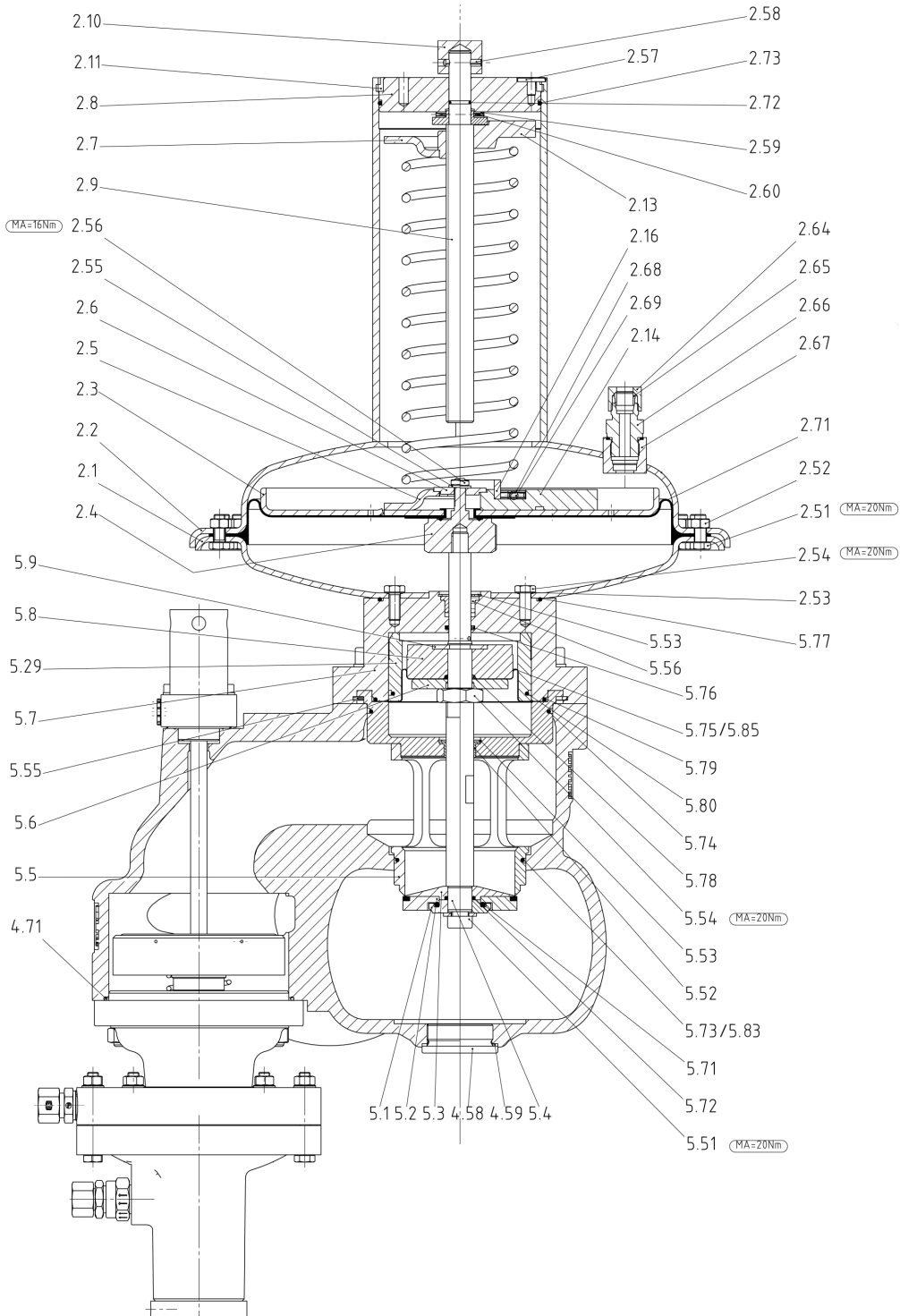

Spare parts kits for HON 380 with RE2 DN 80 - DN 100

Series 380 spare parts kits - PN16/CL150

No.	Name	Qty.	Part no. NBR version (standard)	
			DN 80	DN 100
	Spare parts kit no.		K380-011	K380-015
4.71	O-ring 2-160 W2.62 D133.02	1		20427
2.71	Rolling diaphragm 365*1.1	1		10009046
5.79	O-ring 2-158 W2.62 D120.32	1		20428
5.72/ 5.78	O-ring 2-115 W2.62 D17.12	2		20442
5.71	O-ring 2-217 W3.53 D 29.74	1		20252-RMK
5.73	O-ring W 2.62 D 88.57	1	20518	-
5.83	O-ring 2-156 W2.62 D107.62	1	-	20248
5.74	O-ring 2-159 W2.62 D126.67	1		20491
5.75	Compensating diaphragm, valve seat 80	1	10009134	-
5.85	Compensating diaphragm, valve seat 100	1	-	10009137
5.76	Quad ring 16.20x2.62	1		103838-RMK
5.77	O-ring 2-157 W2.62 D113.97	1		20335
5.80	O-ring 2-154 W2.62 D94.92	1	20449-RMK	-
5.2	Valve plate DN 80	1	10032758	-
5.2	Valve plate DN 100	1	-	10032931
5.52	Plain bearing G1FM-2023-11	1		103836-RMK
5.56	Plain bearing JFM-1622-12	1		103835-RMK
5.53	Locking ring DIN472 - 30 x 1.2	2		103870-RMK
2.53	Sealing ring A 8 X 11.5	4		18710-RMK
2.73	O-ring 2-156 W2.62 D107.62	1		20248

Optional maintenance parts

Optional maintenance parts	Qty.	Part no.		
		DN 80	DN 100	
5.5	Nozzle assembly	1	10032765	10032767
13.1	Noise abatement	1	10032776	1032776

10.4 Spare parts kit for HON 380 with REO

Spare part drawing REO

DN 25 - DN 100

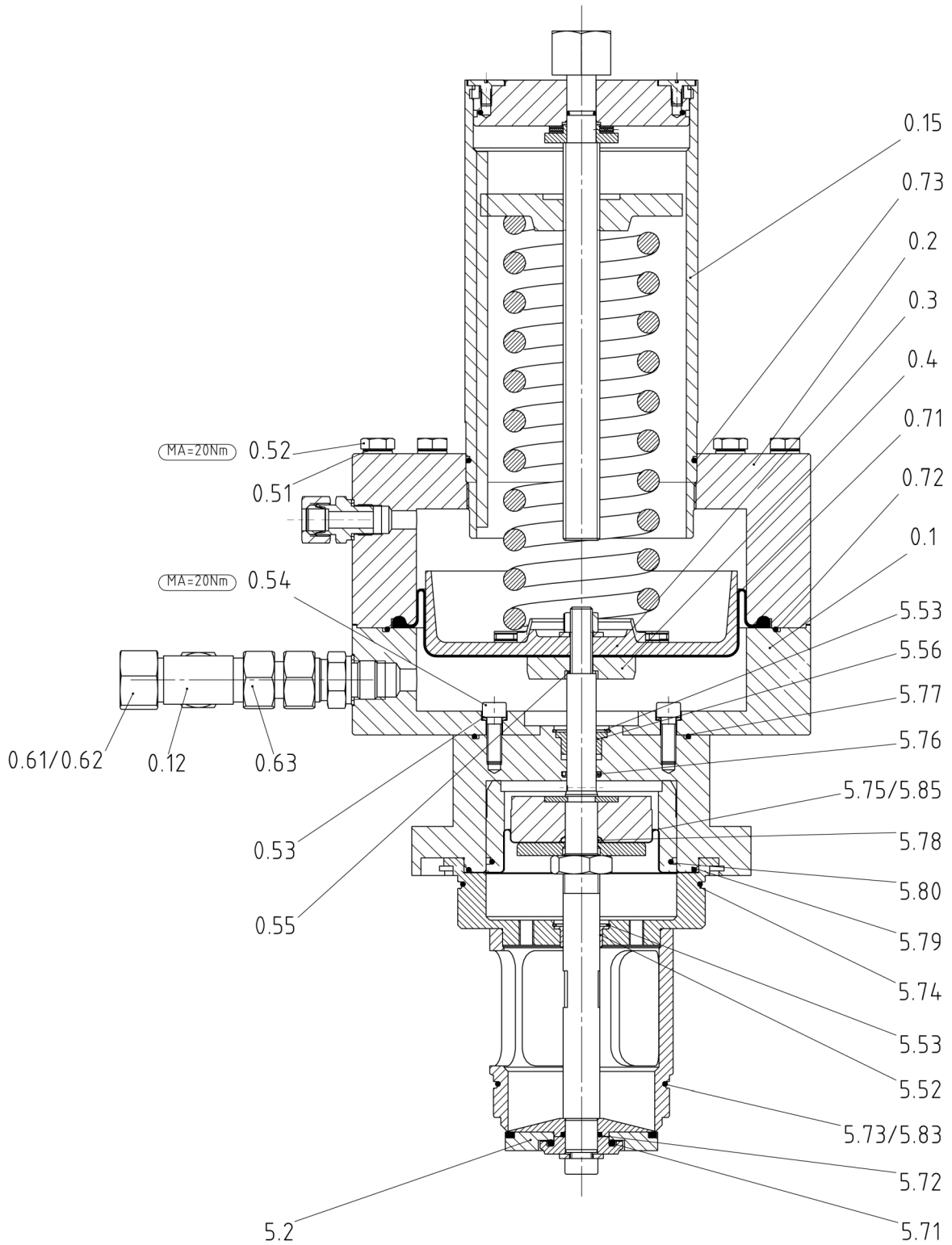

Spare parts kits for HON 380 with REO DN 25 - DN 50

Series 380 spare parts kits - PN16/CL150

No.	Name	Qty.	Part no. NBR version (standard)	
			DN 25	DN 50
	Spare parts kit no.		K380-002	K380-007
4.71	O-ring 2-144 W2.62 D63.17	1		20513-RMK
0.71	REO diaphragm	1		15057061
0.72	O-ring 2-172 W2.62 D209.22	1		20396
2.73	O-ring 2-156 W2.62 D107.62	1		20248
5.71	O-ring 2-117 W2.62 D20.29	1		20383
5.72	O-ring 5-6112 W1.78 D8.74	1		20341
5.73	O-ring 2-146 W2.62 D63.17	1	-	20513-RMK
5.83	O-ring W3.00 D36.20	1	20434-RMK	-
5.74	O-ring 2-149 W2.62 D71.12	1		20308-RMK
5.75	Compensating diaphragm, valve seat 50	1	-	15026002
5.85	Compensating diaphragm, valve seat 25	1	15025011	-
5.76	Quad ring 12.37x2.62	1		103844-RMK
5.77	O-ring 2-157 W3.53 D50.39	1		20325
5.2	Valve plate DN25	1	10032756	-
5.2	Valve plate DN50 chamfer	1	-	10032929
5.52	Plain bearing G1FM-1214-12	2		103843-RMK
5.53	Locking ring DIN472 - 21 x 1	2		103845-RMK
0.53	Gasket A8 X 11.5	4		18710-RMK
0.55	Gasket A8 X 11.5	1		18710-RMK

Spare parts kits for HON 380 with REO DN 80 - DN 100

Series 380 spare parts kits - PN16/CL150

No.	Name	Qty.	Part no.	
			NBR version (standard)	
			DN 80	DN 100
	Spare parts kit no.		K380-012	K380-016
4.71	O-ring 2-160 W2.62 D133.02	1		20427
0.71	REO diaphragm	1		15057061
0.72	O-ring 2-172 W2.62 D209.22	1		20396
5.79	O-ring 2-158 W2.62 D120.32	1		20428
5.72/ 5.78	O-ring 2-115 W2.62 D 17.12	2		20442
5.71	O-ring 2-217 W3.53 D 29.74	1		20252-RMK
5.73	O-ring W 2.62 D 88.57	1	20518	-
5.83	O-ring 2-156 W2.62 D107.62	1	-	20248
5.74	O-ring 2-159 W2.62 D126.67	1		20491
5.75	Compensating diaphragm, valve seat 80	1	10009134	-
5.85	Compensating diaphragm, valve seat 100	1	-	10009137
5.76	Quad ring 16.20x2.62	1		103838-RMK
5.77	O-ring 2-157 W2.62 D113.97	1		20335
5.80	O-ring 2-154 W2.62 D 94.92	1	20449-RMK	-
5.2	Valve plate DN80	1	10032758	-
5.2	Valve plate DN100	1	-	10032931
5.52	Plain bearing G1FM-2023-11	1		103836-RMK
5.56	Plain bearing JFM-1622-12	1		103835-RMK
5.53	Locking ring DIN472 - 30 x 1.2	2		103870-RMK
0.53	Gasket A8 X 11.5	4		18710-RMK
0.55	Gasket A8 X 11.5	1		18710-RMK
2.73	O-ring 2-156 W2.62 D107.62	1		20248

Optional maintenance parts

	Optional maintenance parts	Qty.	Part no.			
			DN 25	DN 50	DN 80	DN 100
5.5	Nozzle assembly	1	10032762	10032747-RMK	10032765	10032767
13.1	Noise abatement	1	10032774	10032775	10032776	1032776

10.5 Lubricants

Lubricants

Important! All parts must be slightly greased.

Use the following lubricants:

Application	Remark	Lubricant	Part no.
O-rings Stationary and moving		Standard version:	
Flat gaskets		Silicone grease (jar)	27079-RMK
Diaphragms	Grease the diaphragm grip body on all sides Do NOT grease the flat grip	Silicone grease (tube)	27081-RMK
Valve spindle sliding surfaces		Low-temperature model:	
Sliding guides		Silicone grease (jar)	103348-RMK
Guide bushings			
Moving parts in SAV control and trip mechanisms	Grease film only	High-temperature model:	
Switch jacks and locking sleeves		PFPE grease	102389-RMK
Control balls and control rollers			
Ball bearing			
Valve sleeves and valve sleeve gaskets in gas pressure regulators		Silicone grease	103348-RMK
Setpoint adjusting screws Power screws			
Thread material combination: Al/Al		Assembly paste	27091
Screw-in fittings and fastening screws			
Spring plate depressions (pilot)			
Devices for oxygen Important! Oil-free and grease-free installation; only antiseize agents are permissible	Upper oxygen pressure limit: 260 bar at 60 °C	Antiseize agent	28211
Devices for ammonia		Antiseize agent	28211

Subject to change without notice



Scan these QR Codes to see how Honeywell's integrated gas solutions can help you to better manage your gas assets and optimize your value chain.

Additional information

To learn more about Honeywell's product contact your Honeywell Process Solutions representative, or visit www.honeywellprocess.com or www.hongas-tec.de.

Honeywell Process Solutions

1250 West Sam Houston Parkway
South
Houston, TX 77042
Phone: 1-602-293-1866 Option 4

Honeywell Gas Technologies GmbH
Osterholzstrasse 45
34123 Kassel, Germany
Phone: +49 (0) 561 5007111

Emaar Business Park, Building 2,
Sheikh Zayed Road, PO Box 232362
Dubai, United Arab Emirates
Phone: +97144505800

Honeywell Engineering Sdn Bhd
1st Floor, Block B, No.10
Jalan Bersaru 13/4
46200, Petaling Jaya Selangor DE, Malaysia
Phone: +603 7626 57000

A1 Building, C&W Industry Zone
No.14, Jiuxiangqiao Rd., Chaoyang District,
Beijing, P.R. China 100015
Phone: +8610-56696001

www.honeywellprocess.com
www.hongas-tec.de

September 2022
© 2022 Honeywell International Inc.

Honeywell